

SIMRAD

AP70/AP80

Installation Manual

ENGLISH



Preface

Disclaimer

As Navico is continuously improving this product, we retain the right to make changes to the product at any time which may not be reflected in this version of the manual. Please contact your nearest distributor if you require any further assistance.

It is the owner's sole responsibility to install and use the equipment in a manner that will not cause accidents, personal injury or property damage. The user of this product is solely responsible for observing safe boating practices.

NAVICO HOLDING AS AND ITS SUBSIDIARIES, BRANCHES AND AFFILIATES DISCLAIM ALL LIABILITY FOR ANY USE OF THIS PRODUCT IN A WAY THAT MAY CAUSE ACCIDENTS, DAMAGE OR THAT MAY VIOLATE THE LAW.

Governing Language: This statement, any instruction manuals, user guides and other information relating to the product (Documentation) may be translated to, or has been translated from, another language (Translation). In the event of any conflict between any Translation of the Documentation, the English language version of the Documentation will be the official version of the Documentation.

This manual represents the product as at the time of printing. Navico Holding AS and its subsidiaries, branches and affiliates reserve the right to make changes to specifications without notice.

Compliance

The AP70 and AP80 systems complies with the following regulations:

- Wheelmark directive 2002/84 EC (HCS and HSC)
- CE (2004-108 EC EMC Directive) - AP70 systems when used with an AC70 computer
- C - Tick

→ **Note:** AP70 systems are not wheelmark approved when used with an AC70 computer.

For more information please refer to our websites:

www.navico.com/commercial and www.simrad-yachting.com.

The Wheelmark

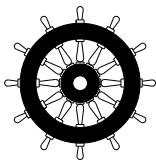

The AP70 and AP80 systems are produced and tested in accordance with the European Marine Equipment Directive 96/98. This means that the systems comply with the highest level of tests for nonmilitary marine electronic navigation equipment existing today.

The Marine Equipment Directive 96/98/EC (MED), as amended by 98/95/EC for ships flying EU or EFTA flags, applies to all new ships, to existing ships not previously carrying such equipment, and to ships having their equipment replaced.

This means that all system components covered by annex A1 must be type-approved accordingly and must carry the Wheelmark, which is a symbol of conformity with the Marine Equipment Directive.

While the autopilot system may be installed on vessels not needing to comply with the Marine Equipment Directive, those requiring compliance must have one Control unit set-up as a "master unit" in order for the installation to be approved.

Navico has no responsibility for the incorrect installation or use of the autopilot, so it is essential for the person in charge of the installation to be familiar with the relevant requirements as well as with the contents of the manuals, which covers correct installation and use.

Copyright

Copyright © 2015 Navico Holding AS.

Warranty

The warranty card is supplied as a separate document.

In case of any queries, refer to the our websites:
www.navico.com/commercial and www.simrad-yachting.com.

About this manual

This manual is a reference guide for installing and commissioning the Simrad AP70 and AP80 Autopilot Systems.

The manual will be continuously updated to match new sw releases. The latest available manual version can be downloaded from our web sites.

Important text that requires special attention from the reader is emphasized as follows:

→ **Note:** Used to draw the reader's attention to a comment or some important information.

⚠ Warning: Used when it is necessary to warn personnel that they should proceed carefully to prevent risk of injury and/or damage to equipment/personnel.

Contents

7	Introduction
7	Wheelmark approval
7	Spare parts and accessories
7	System overview
11	Autopilot Control units
12	Autopilot computers
14	Computer boards
17	Mounting
17	General
17	Mounting location
17	AP70 and AP80 control units
20	Autopilot computers
21	Wiring
21	Wiring guidelines
21	The autopilot system, basic wiring principles
22	The CAN bus
23	Power supply
25	FU80, NF80 and QS80 Remote control units
25	Steering levers
26	NMEA 2000 and SimNet devices
26	IEC61162-1/2 (NMEA 0183) devices
27	Autopilot computers
28	Drive units
33	Rudder feedback
35	Alarm interface
36	External I/O
39	External system selection
39	External mode selection - pulse
40	ECDIS system
40	Backup navigator alarm
41	System configuration
41	General
41	The settings dialog and submenus
41	Turning on for the first time
42	Network settings
46	Installation settings
54	Seatrials
55	Tuning the autopilot for optimum steering performance
58	The alarm system
58	Message types
58	Alarm indication
59	Acknowledging a message
59	The alarm dialogs
60	Setting the alarm and warning limits
60	Fallback and failures during automatic steering
61	List of possible alarms and corrective actions

66	Installation checklist
66	General
66	Checklist
67	Installation settings
69	Installed unitsw
70	Specifications
70	AP70 and AP80 Autopilot system
71	AP70 and AP80 Control units
72	Autopilot Computers
74	Computer boards
77	AP70 and AP80 Connector pinouts
78	Supported data
79	Drawings
79	AP70 Control unit
80	AP80 Control unit
81	AC70 and SI80 Computer
81	SD80 and AD80 Computers
82	AC80A and AC80S Computer
82	AC85 Computer

1

Introduction

Wheelmark approval

The AP70 and AP80 systems are produced and tested in accordance with the European Marine Equipment Directive 96/98. This means that these systems comply with the highest level of tests for non-military marine electronic navigation equipment existing today.

While the AP70/AP80 may be installed on vessels not needing to comply with the Marine Equipment Directive, those requiring compliance must have one control unit set-up as a “master unit” in order for the installation to be approved.

Navico has no responsibility for the incorrect installation or use of the autopilots, so it is essential for the person in charge of the installation to be familiar with the relevant requirements as well as with the contents of this manual, which covers correct installation of the autopilot system.

- **Note:** AP70 systems are not wheelmark approved when used with an AC70 computer.
- **Note:** When a complete system (e.g. an autopilot system) is wheelmark approved, only the main unit(s) in the system identifies the wheelmark approval (wheelmark symbol on the label or reference in the software). This to avoid the misunderstanding that all optional units in a system retain their wheelmark approval even if they are installed in a not approved system. The type examination certificate (MED-B) for the wheelmarked system lists all optional equipment that is part of the wheelmark approval. The EC Declaration of Conformity do also show which units that are part of the approval.

Spare parts and accessories

List of spare parts and accessories for the AP70/AP80 system can be found on our websites.

System overview

The AP70/AP80 systems include several modules that need to be mounted in different locations on the vessel and that need to interface with at least three different systems on the boat:

- The boat’s steering system
- The boat’s electrical system (input power)
- Other equipment onboard

It is important to become familiar with the configuration of the system prior to beginning the installation. Refer to illustrations on page 8 onwards.

AP70, simple system example

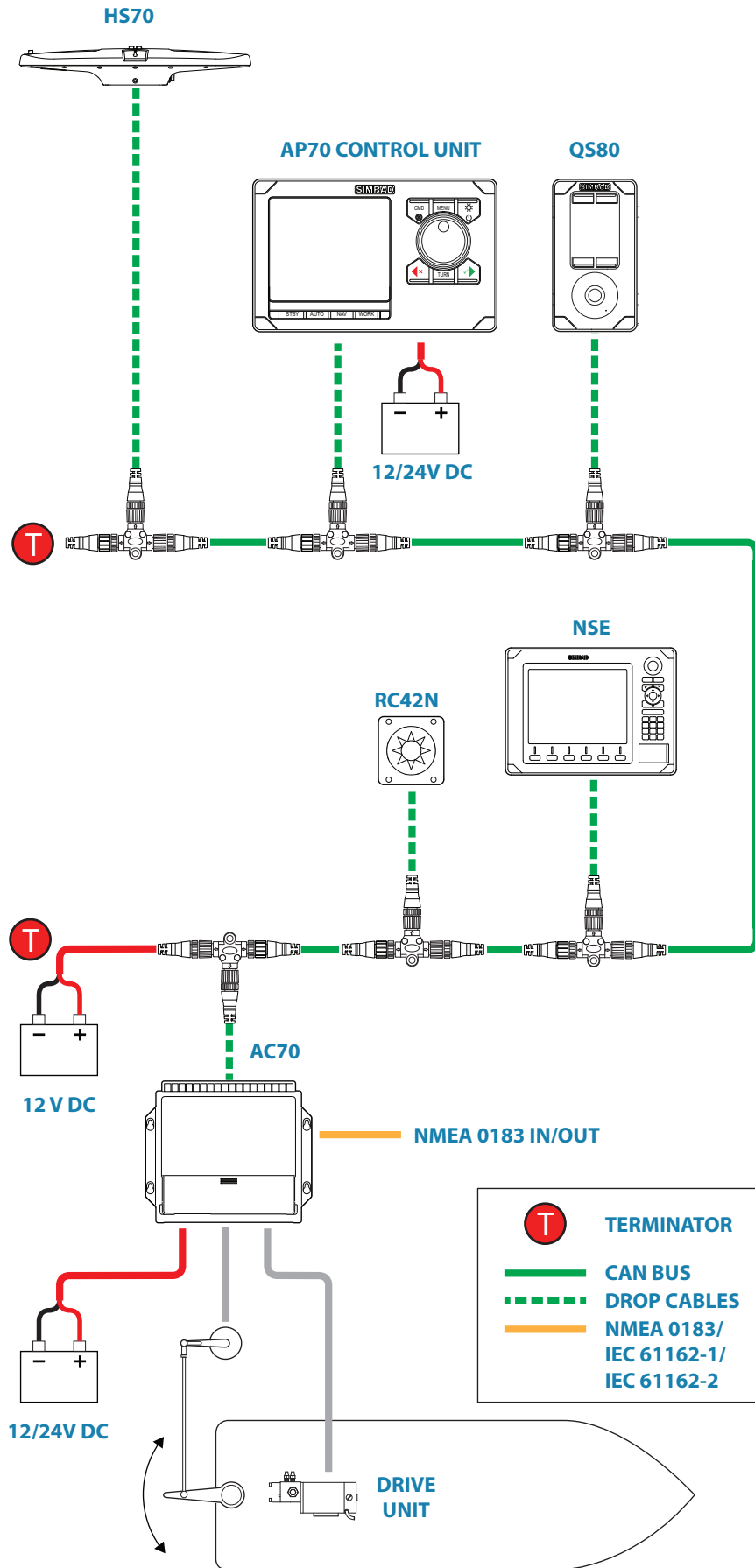

AP80, simple system example

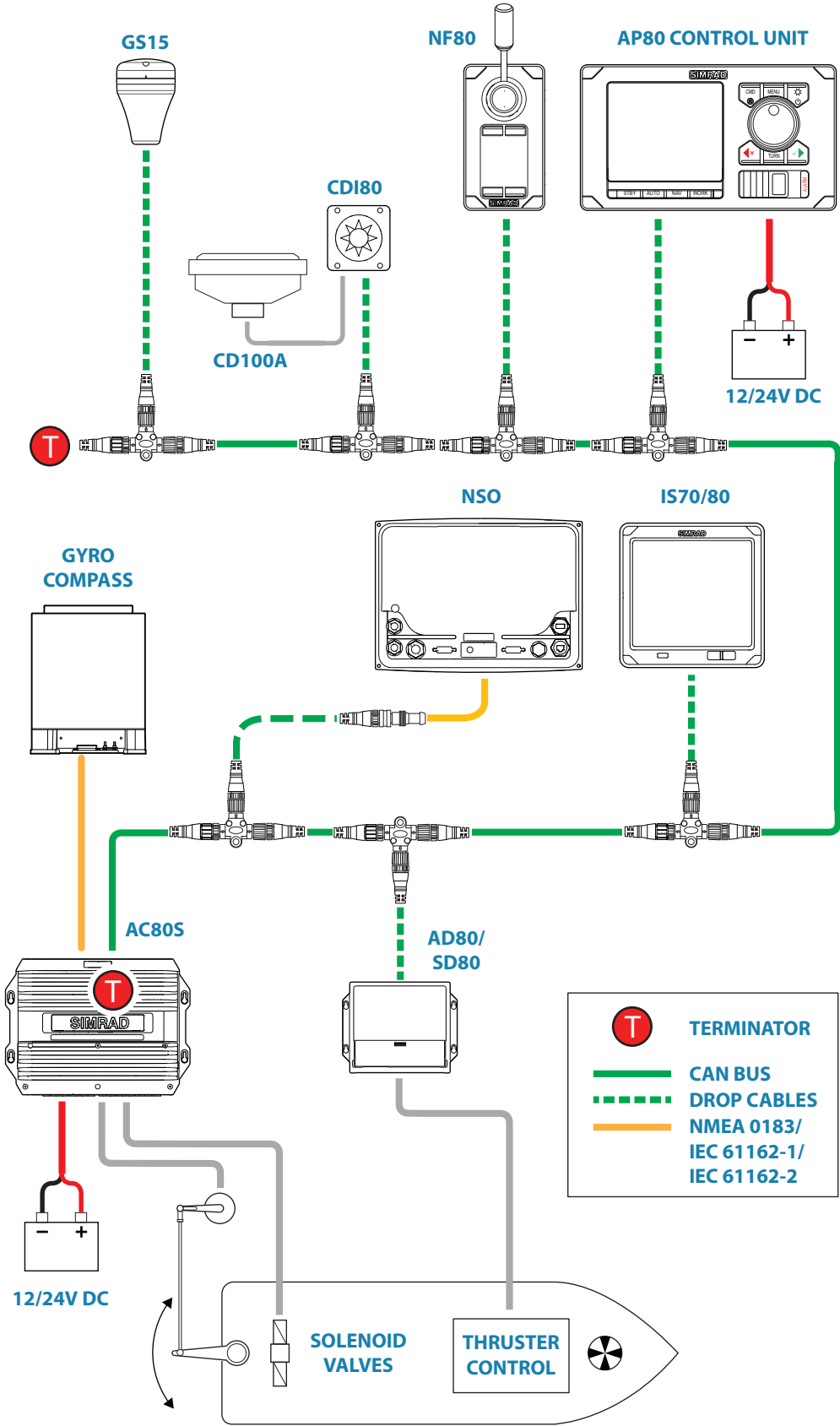

AP80, Wheelmark-approved system example

→ **Note:** For IMO approval, other equipment must be connected via an SI80 board located in an SI80, AC80A, AC80S or AC85 computer.

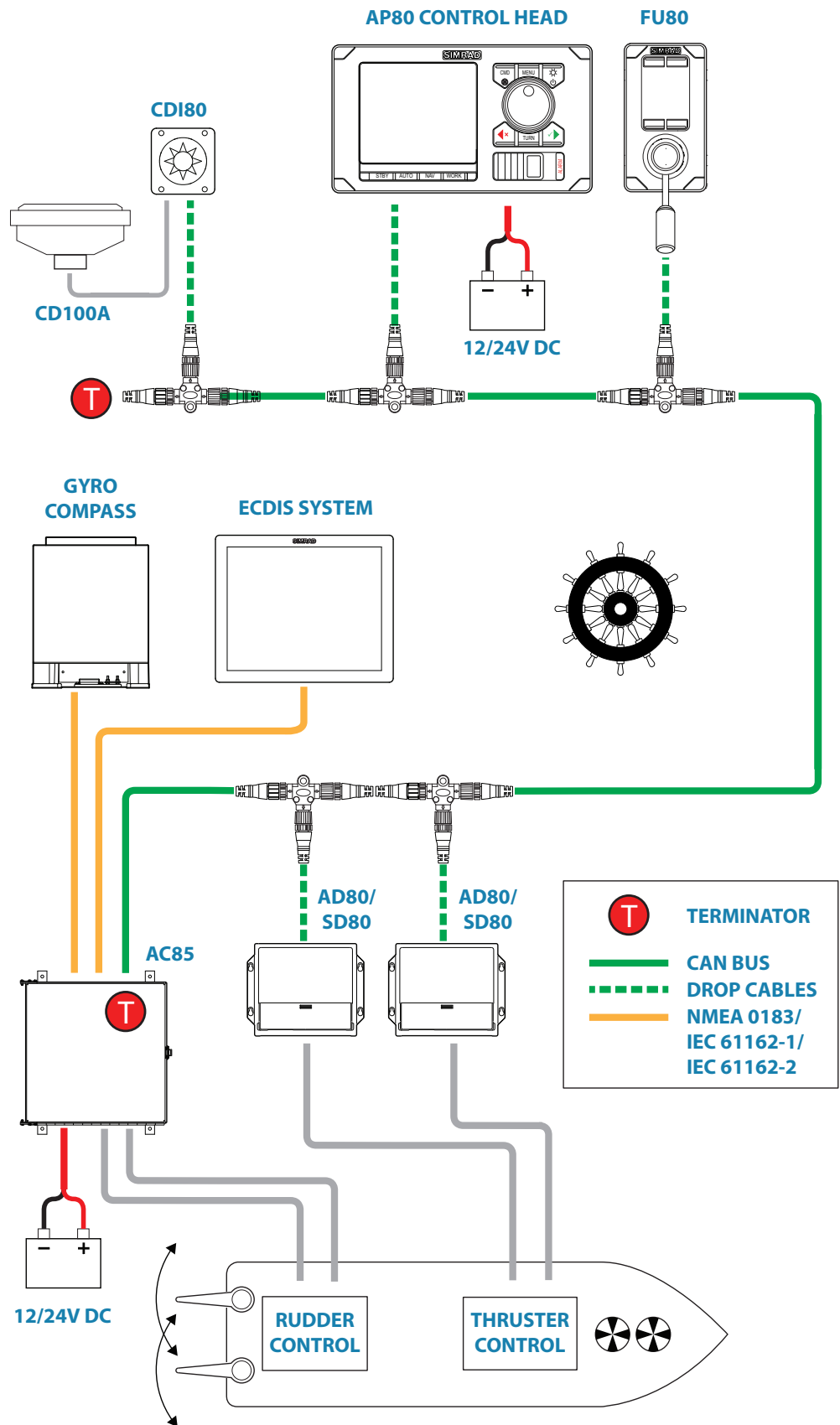

Autopilot Control units

Front - controls

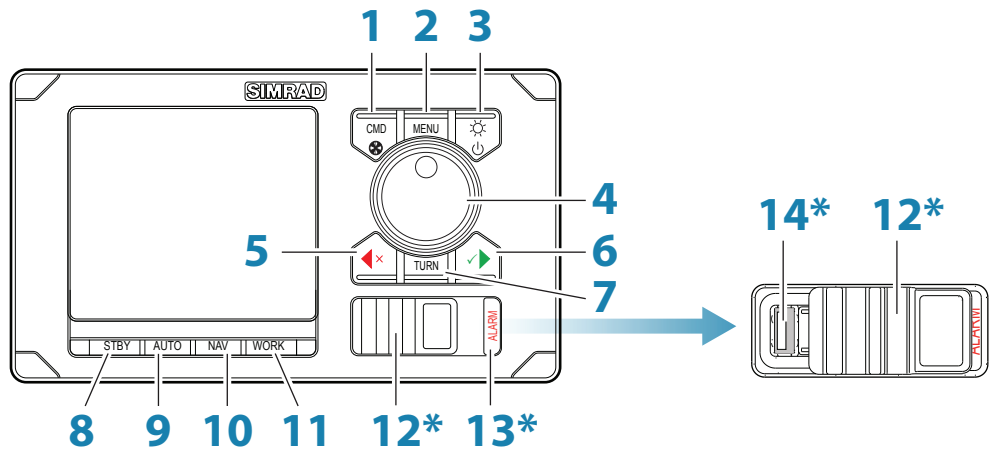

→ * Available on AP80 control units only.

No.	Key/Description
1	CMD/THRUSTER. A short press takes/requests command. A long press (3 seconds) activates/deactivates available thrusters
2	MENU. A short press displays the active steering mode's quick menu. A second click displays the Settings menu
3	POWER/LIGHT. A short press displays the Light dialog. A long press (3 seconds) turns the unit ON/OFF
4	ROTARY KNOB (Course wheel). Rotated for selecting menu item and adjusting value, pressed to confirm a selection/entry. For mode specific operation, refer to the Operator manual
5	PORT (Cancel). Exits menu/returns to previous menu level. Activates NFU steering when in Standby mode. Changes set heading, set course and track offset to port.
6	STBD (Confirm). Confirms menu selection/enters next menu level. Activates NFU when in Standby mode. Changes set heading, set course and track offset to starboard.
7	TURN. Displays the Turn dialog
8	STBY. Turns the autopilot to Standby mode
9	AUTO. Activates Auto and NoDrift mode
10	NAV (AP70) / TRACK (AP80). Activates Nav or Track steering mode
11	WORK. Used for selecting work profile
12	USB port door
13	ALARM. Displays the Alarm listing dialog
14	USB connector

AP80 control units only

Rear - connectors

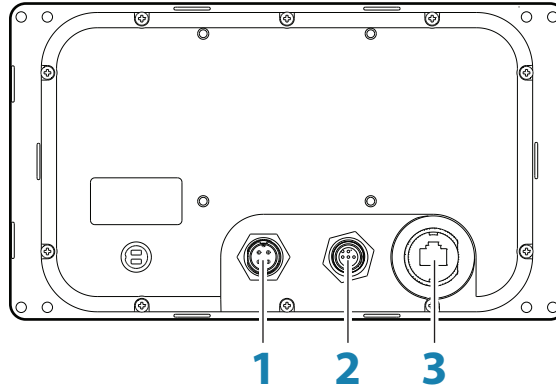

No.	Connector/Description
1	4 pin connector for 12/24 V DC local power, External alarm/Active unit OUT
2	Micro-C connector for CAN bus
3	Ethernet network port, used for sw update

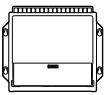

SD80
AD80

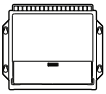

AC70
SI80



AC80A
AC80S

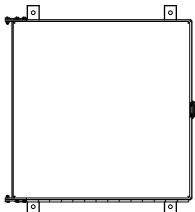

AC85

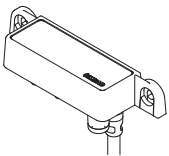

SG05
PRO

Autopilot computers

The AP70/AP80 systems use a combination of 5 different enclosures and 4 boards to form a flexible computer and interface system.

There are 7 standardized and 1 customized computers with built-in and optional boards as shown below.

Refer "Computer boards" on page 74

SG05 PRO

The SG05 PRO Autopilot Computer provides autopilot control from AP70 and AP80 control units to CAN bus/EVC steering systems.

The SG05 PRO receives sensor data (drive/rudder angle and boat speed) from the EVC, does steering calculations and sends drive/rudder commands back to the EVC system which brings drive/rudder to commanded angle.

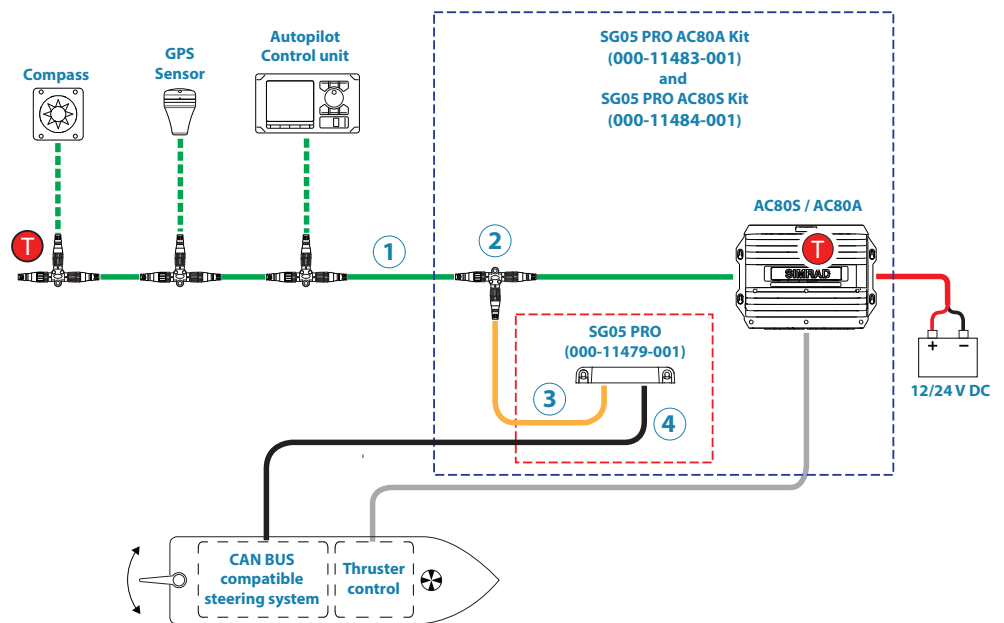

Item	Description
1	Micro-C backbone
2	Micro-C T-joiners
3	SimNet to Mircor-C (male) Drop cable
4	SD05 Cable, female
T	Terminators

→ **Notes:**

- For IMO approval, the system must contain AC80S or AC80A Computer.
- A separate Installation Guide if delivered with the SG05 unit.

Standard computers

The standardized computers have the following built-in boards:

Computer	AC70 board	AD80 board	SD80 board	SI80 board
AC70	x			
SI80				x
AD80		x		
SD80			x	
AC80A		x		x
AC80S			x	x
SG05 PRO	For CAN bus compatible steering system			

Customized computer

The AC85 computer is supplied with 1 SI80 board, and have space for up to 3 additional boards:

Computer	AC70 board	AD80 board	SD80 board	SI80 board
AC85	Optional	Optional	Optional	x 1 Optional

Computer boards

Indicator diodes and switches

Indicator diodes and switches are available on the boards as shown in the tables below.

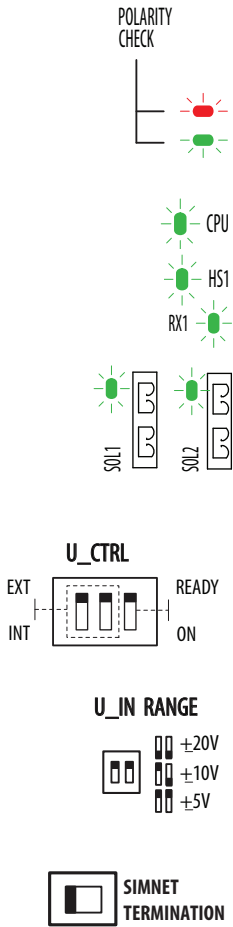

LED	Description	AC70	AD80	SD80	SI80
Polarity check	Red: wrong polarity Green: correct polarity	x			x
CPU	1Hz alternating green: CPU is running correctly Rapid flashing: Application program is missing	x	x	x	x
HS	Green: Handshake output is on		x	x	
RX	Living green: Serial data is received	x			x
SOL	Green: Solenoid command is given			x	

Switch	Description	AC70	AD80	SD80	SI80
U_CTRL	Selection of internal ± 10 V or external reference voltage for analog voltage control output. → Note: For 4-20 mA current control, switches must be set to internal ref. voltage		x		
U_IN RANGE	Range setting of analog voltage input signal for rudder feedback, follow up wheel or remote DP control		x	x	
SIMNET TERMINATION	ON (to the left) or off setting of 120 ohm CAN bus termination. → Note: Termination must be set to ON when the board is at one end of the CAN bus backbone, otherwise it must be set to OFF.				x

AC70 board

Drive computer board for rudder or propeller (i.e. Voith Schneider) for reversible motor or galvanic non-isolated solenoids.

Includes:

- SUPPLY - power supply 12/24 V in
- DRIVE - output for Motor or solenoid command
- DRIVE ENGAGE - output for clutch/bypass valve or automode signal for oil flow valve etc
- ALARM - Output for external alarm buzzer
- NMEA 0183 - in/out for IEC 61162-1, -2 and NMEA 0183
- RUDDER - Input for frequency rudder feedback
- REMOTE - Input for NFU steering lever
- MODE - Input for external mode selector
- SIMNET - connection to CAN network

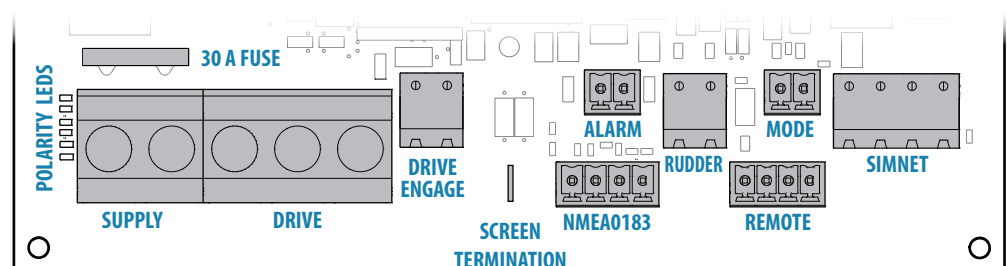
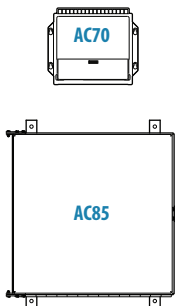

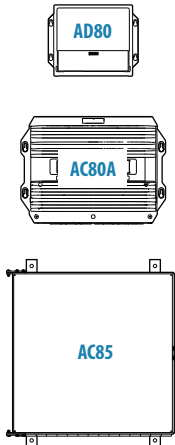

AD80 board

Drive computer board for rudder or thruster, supporting analog voltage or low current signals for angle or proportional control.

Includes:

- UI CTRL - output for analog voltage low current command
- RUD UI - Input for analog (voltage or current) rudder feedback
- RUD FRQ - Input for frequency rudder feedback
- READY - output for ready contact when board is up running ready for control
- HS1 - Generic in/out handshake signal port 1
- HS2 - Generic in/out handshake signal port 2
- MODE - Input for external mode selector
- SIMNET - connection to CAN network

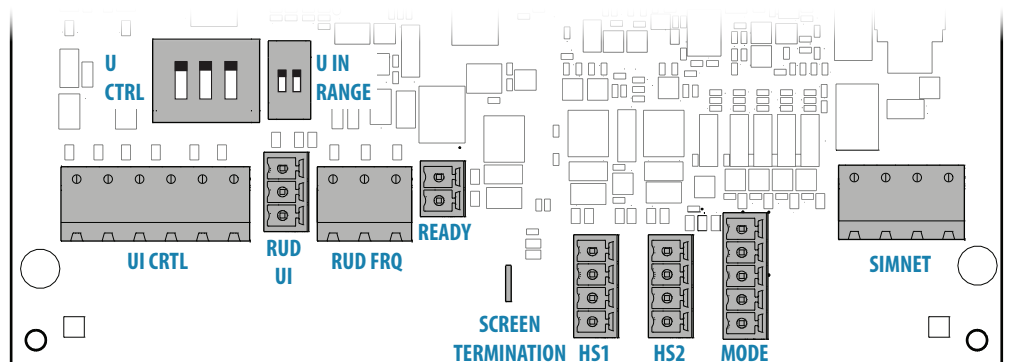

SD80 board

Drive computer board for rudder or thruster, supporting galvanic isolated solenoids or high current signals for angle or proportional speed control.

- Includes:
- RUD UI - Input for analog voltage or current rudder feedback
- RUD FRQ - Input for frequency rudder feedback
- SOLENOIDS - Galvanic isolated output for solenoid command
- ENGAGE - For operating bypass or dual speed valve, clutch etc for hydraulic or mechanical drive units
- READY - output for ready contact when board is up running ready for control
- HS1 - Generic in/out handshake signal port 1
- HS2 - Generic in/out handshake signal port 2
- MODE - Input for external mode selector
- SIMNET - connection to CAN network

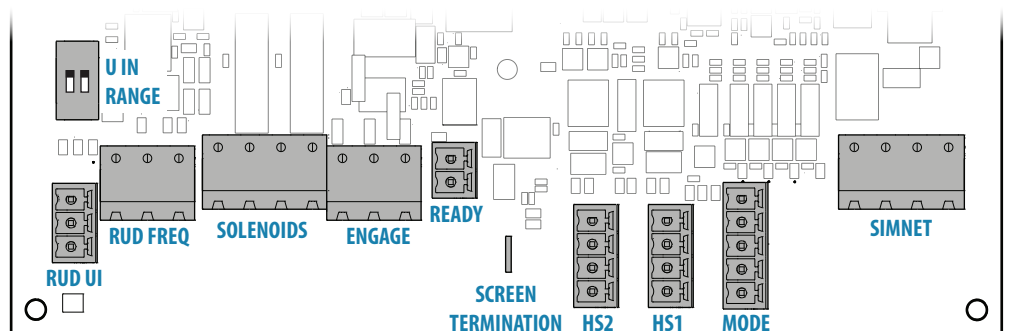
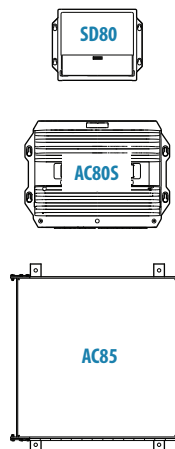



SI80 board

A four channel NMEA 0183 interface computer board and voltage supply for CAN bus.

Includes:

- SIMNET TERMINATION - Switch for CAN bus termination ON/OFF
- SIMNET - SimNet 15 V out
- REMOTE - Input for NFU steering lever
- NMEA 0183 CH.. - 4 i/o NMEA/IEC 61162-1/IEC 61162-2 channels
- SUPPLY - power supply 12/24 V in

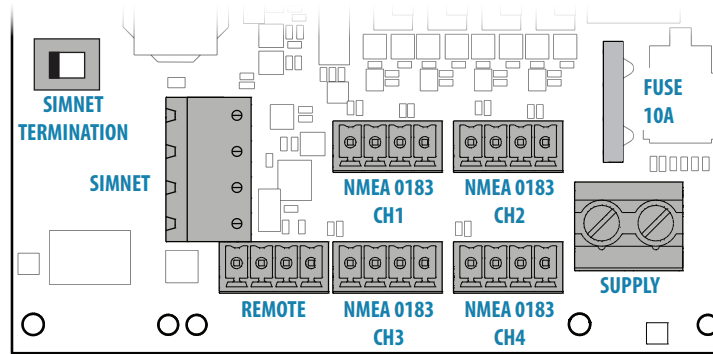

2

Mounting

General

Mechanical installation of optional equipment are described in separate manuals following the units. These manuals can also be downloaded from our websites: www.navico.com/commercial and www.simrad-yachting.com.

Mounting location

The units should be mounted with special regard to the units' environmental protection, temperature range and cable length. Poor ventilation may cause the units to overheat. wRefer "Specifications" on page 70.

The mounting location must allow for required working area when connecting the cables. Also ensure that the location for the computer units allows viewing the board's LED indicators.

The mounting surface needs to be structurally strong, with as little vibration as possible. If possible mount the unit close to the edges of a panel to minimize vibration.

Ensure that any holes cut are in a safe position and will not weaken the boat's structure. If in doubt, consult a qualified boat builder. Ensure that there are no hidden electrical wires or other parts behind the panel.

The control unit should be mounted so that the operator can easily use the controls and clearly see the display screen. For best results install the display out of direct sunlight, and on a location that have minimal glare from windows or bright objects.

When panel mounting the control unit and the remotes, the mounting surface must be flat and even to within 0.5 mm.

The units conforms to the appropriate Electromagnetic Compatibility (EMC) standards, but proper installation is required to get best use and performance from this product. Ensure you have as much separation as possible between different electrical equipment.

AP70 and AP80 control units

Avoid mounting a control unit where it is easily exposed to sunlight, as this will shorten the lifetime of the display. If this is not possible, make sure the unit is always covered with the optional protective cover when not in use.

Panel (flush) mount

1. Attach the mounting template to the selected mounting position
 2. Drill pilot holes for the 4 hole saw cuts and for the 4 self tapping screws used to secure the unit. If using M4 machine screws use a 5 mm (0.20 ") drill bit
 3. Use a 25 mm (1 ") hole saw to cut the four corner radius
 4. Cut along the dotted line and remove waste material
 5. Peel backing off the gasket and apply it to the unit (A)
 6. Connect the cables to the rear of the unit before placing the unit into the console
 7. Secure the display to the surface with 4 screws (B)
 8. Firmly clip the bezel in place (C)
- **Note:** For AP80 the bezel may not be used for flush/low profile installations.

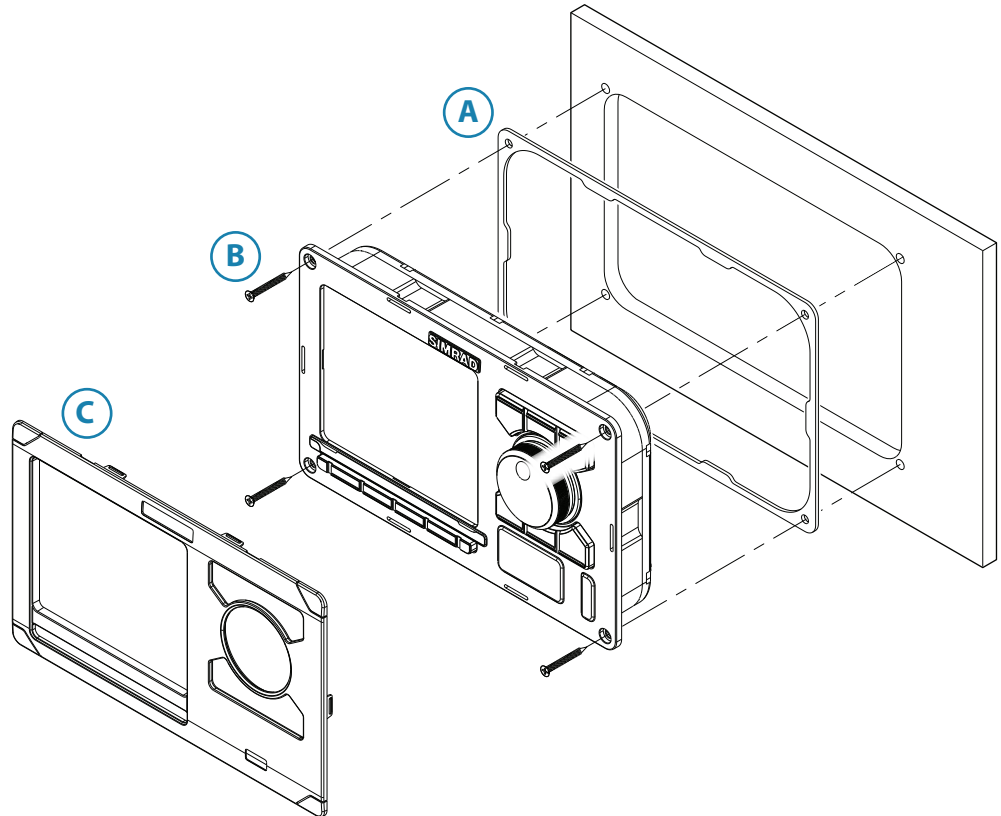

Bracket mount (option)

→ **Note!** When the control unit is bracket-mounted, it is not weatherproof from the back due to a breathing hole in the back cabinet. When bracket-mounted, the exposed parts of the plugs should be protected against salt corrosion.

1. Use the bracket base as a template to mark the screw hole location
2. Drill pilot holes and hole for cables if required
3. Secure the bracket base to the surface
4. Secure the bracket's adapter to the rear of the control unit using the 4 screws supplied with the bracket
5. Align the bracket base with the cradle and partially screw in the bracket knobs one at a time
6. Adjust the unit for best viewing angle, and tighten the bracket knobs

1 - 3

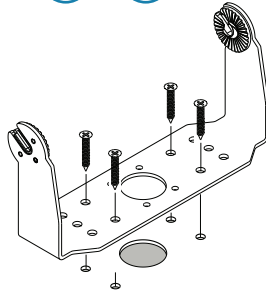

4

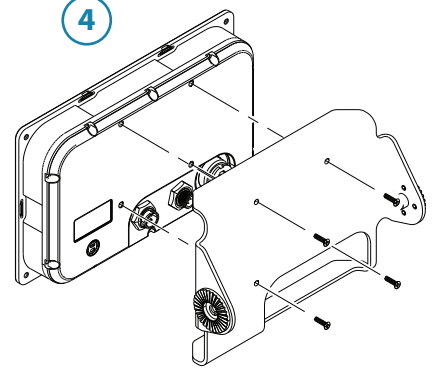

5

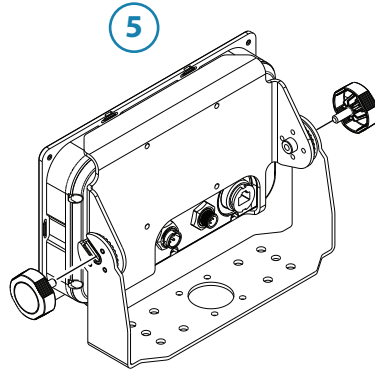

6

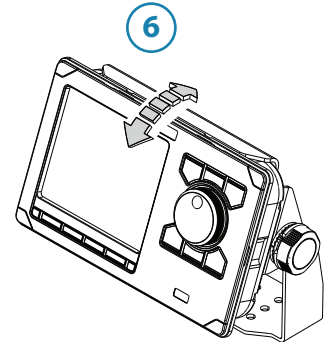

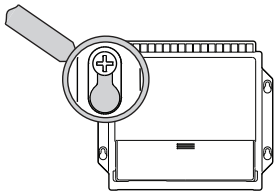

Autopilot computers

The mounting location must allow for required working area when connecting the cables. Also ensure that the location for the computer units allows viewing the board's LED indicators.

The mounting surface needs to be structurally strong, with as little vibration as possible. If possible mount the unit close to the edges of a panel to minimize vibration.

Ensure that any holes cut are in a safe position and will not weaken the boat's structure. If in doubt, consult a qualified boat builder. Ensure that there are no hidden electrical wires or other parts behind the panel.

Preferably mount the computers with the cable entries exiting downwards.

Mount the cable retainer included with the AC70, SI80, SD80 and AD80 on the wall beneath the unit.

An isolating gasket is included with the AC80A/AC80S computers. This must be used as a galvanic isolator if the unit is mounted on a metal surface.

The SG05 PRO Autopilot Computer has 2 SimNet ports to connect either via a drop-cable or inline as part of the network backbone.

For Micro-C based networks use the SimNet to Micro-C (male) converter cable p/n 24005729.

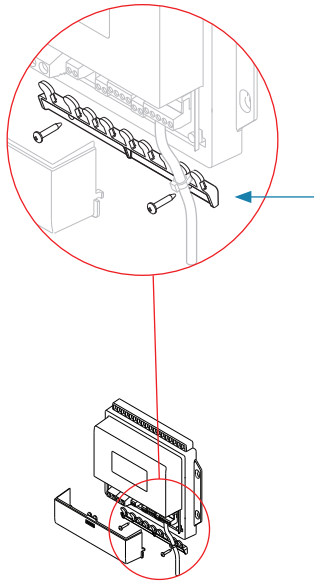

AC70/SI80

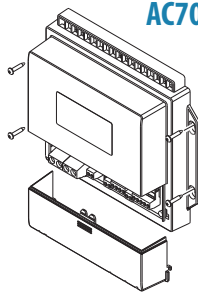

AC80A/AC80S

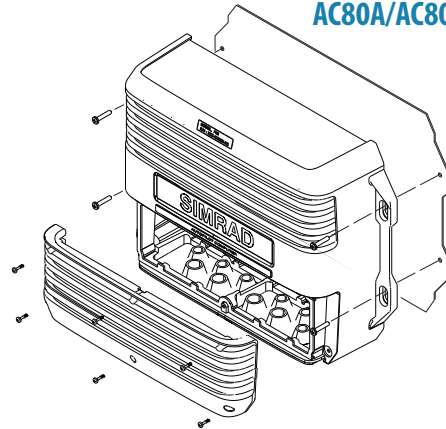

SD80/AD80

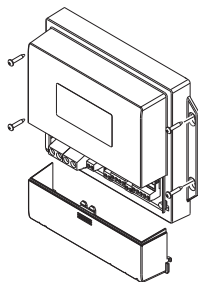

SG05 PRO

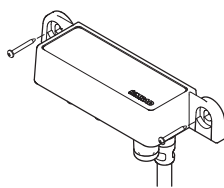

AC85

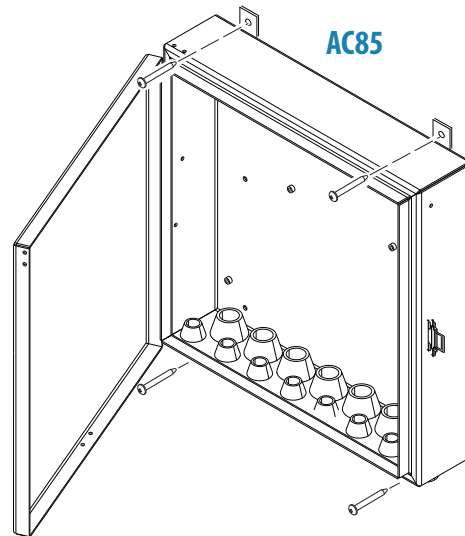

→ **Note:** The autopilot computers are not waterproof. Refer "Specifications" on page 70.

3

Wiring

Wiring guidelines

CAN network cables and other signal cables (i.e. compass, feedback, NMEA) should not be run in parallel with other cables carrying radio frequency or high current, such as VHF and SSB transmitters, battery chargers/generators, and winches.

Don't make sharp bends in the cables, and avoid running cables in a way that allows water to flow down into the connectors. If required, make drip and service loops.

If cables are shortened, lengthened or re-terminated, do insulate and protect all wiring connections.

Most of the units are communicating on the CAN bus with drop cables. Try mounting the units within the standard cable length supplied with each unit. Additional cables and cable extensions are available from our distributors.

⚠ Warning: Before starting the installation, be sure to turn electrical power off. If power is left on or turned on during the installation, fire, electrical shock, or other serious injury may occur. Be sure that the voltage of the power supply is compatible with the spec for the units!

The autopilot system, basic wiring principles

The AP70 and AP80 autopilot system use a CAN bus backbone which makes it simple to interface to SimNet and NMEA 2000 devices.

NMEA 0183 devices, rudder feedbacks and other control devices connects to an autopilot computer.

In a standard system the CAN bus is powered by the AC80A, AC80S, SI80 or AC85 Autopilot computer. The AP70/AP80 control units have separate power supply. Other SimNet/NMEA devices are powered by the CAN bus.

The following sections describe installation of the components listed in the illustration below. Refer to separate manuals for detailed information about each interfacing unit.

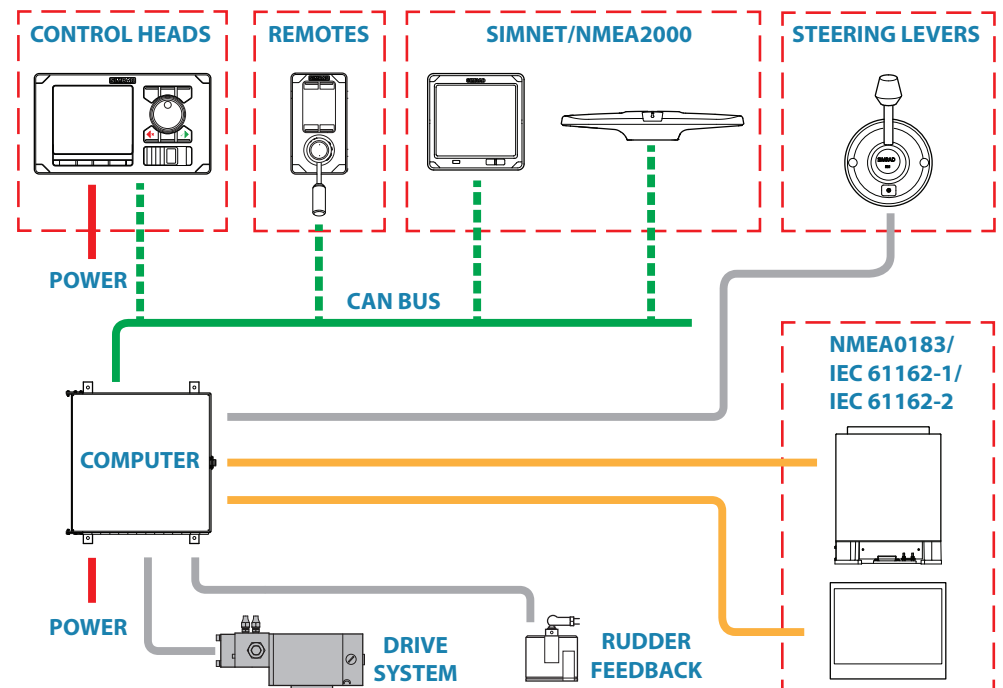

The CAN bus

The CAN bus is based on the well known SimNet plug & play concept and on the NMEA 2000 SAE J1939 protocol. Hard wiring is based on standard NMEA 2000 cables with Micro-C type connectors and joiners.

The bus consists of a linear backbone using drop cables and Micro-C T-joiners for connecting NMEA 2000 and SimNet devices.

The bus has a maximum cable length of 150 m (500 ft), and a drop cable has a maximum length of 6 m (20 ft).

In a default autopilot system the CAN bus backbone expands from the AC80A or AC80S Autopilot computer, which supplies power to the backbone. There will always be a female connector in the expanding end of the backbone cables.

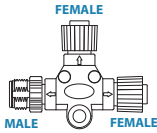

For powering the CAN bus, see “Powering the CAN bus” on page 23.

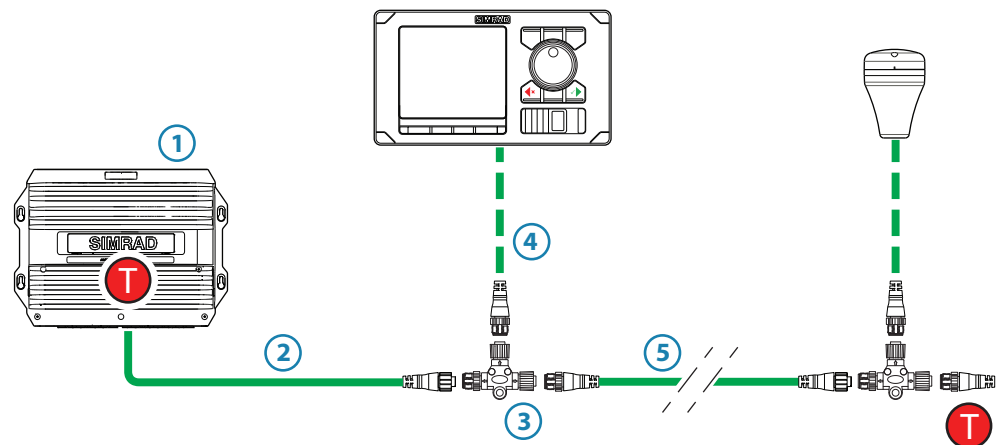

Key	Description
1	AC80 Autopilot computer with built-in CAN bus terminator on the SI80 board
2	0,6 m (2 ft) pigtail cable, female connector
3	Micro-C T-joiner
4	CAN bus Drop cable, connectors in each end (female - male)
5	CAN bus Backbone, various lengths available. Connectors in each end
T	Terminator, 120 ohm, male

→ **Note:** If cables are not supplied by Simrad, ensure that they meet NMEA 2000/IEC61162-1/2 requirements.

Planning and installing a network backbone

- Plan the network carefully
 - It is recommended to create a diagram of the network prior to starting the installation
- Run the backbone between the locations of all CAN devices you want to install
 - It must be less than 6 m (20 ft) cable run from a device to the backbone
- Consider the load/current draw from the devices
 - Refer “Network LEN” on page 24

For network cables and components, refer to our website.

Terminating the CAN bus

The CAN bus must have a terminator at each end of the backbone.

In a default autopilot system the CAN bus expands from the AC80A, AC80S or AC85 Autopilot computer. This computer includes a terminator on the SI80 board, enabled by the micro switch.

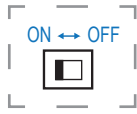

- Set the switch to ON when the SI80 board is at the end of the CAN bus
- Set the switch to OFF when the SI80 board is used as additional power supply to the CAN bus

Factory default setting of SI80 terminator is OFF.

For location of the dip switch, refer to the illustrations inside the computer unit.

A terminator in the other end of the CAN bus can be of the following:

- An SI board (in SI80, AC80A, AC80S or AC85 computer) with enabled terminator
- A power cable with built in terminator (plug marked 120 ohm)
- A single terminator plug (marked 120 ohm)

Shield connection

It is required to use shielded cables to meet radio frequency interference requirements as defined in the NMEA 2000 specification:

- The shield shall not be electrically connected within the interface to the electronic device chassis or ground
- The shield shall be electrically continuous through the network connection
- The shield shall be connected to ground at a single point, normally the ship's ground at the source of network power

Power supply

- **Note:** Wheelmark/US Coast Guard approved systems require a Power Failure alarm. In such installations the master station control unit and the autopilot computer with the SI80 board for CAN bus supply must be connected to different independent power supplies.
- **Note:** It is recommended to install an external on/off switch for the Autopilot Computer power supply.
- **Note:** Do not connect the power cable to the same terminals as the start batteries, drive units, thruster or other high current products
- **Note:** If joining to an existing NMEA 2000 network or similar CAN bus network that has its own power supply, use an NMEA 2000 Gateway to isolate the two power supplies.

Powering the CAN bus

In a default autopilot system the SI80 board (in the SI80, AC80A, AC80S or AC85 computer) is used for powering the CAN bus backbone.

For larger systems additional power should be added at a central point in the backbone to balance the voltage drop of the network. Additional power should be supplied by using an SI80 board. Refer "Network LEN" on page 24.

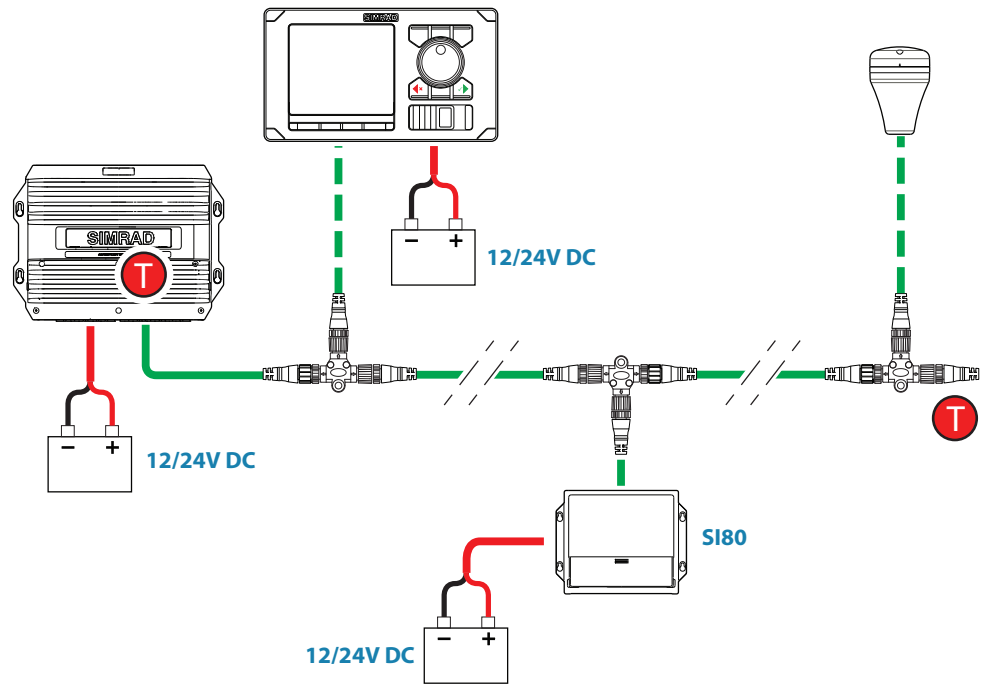

Network LEN

When you have a larger system with network power in center of the backbone you should make the installation such that the load/current draw from the devices in each side/branch is equal.

For LEN numbers, see "Specifications" on page 70.

→ **Note:** 1 LEN (Load Equivalency Number) equals 50 mA current draw.

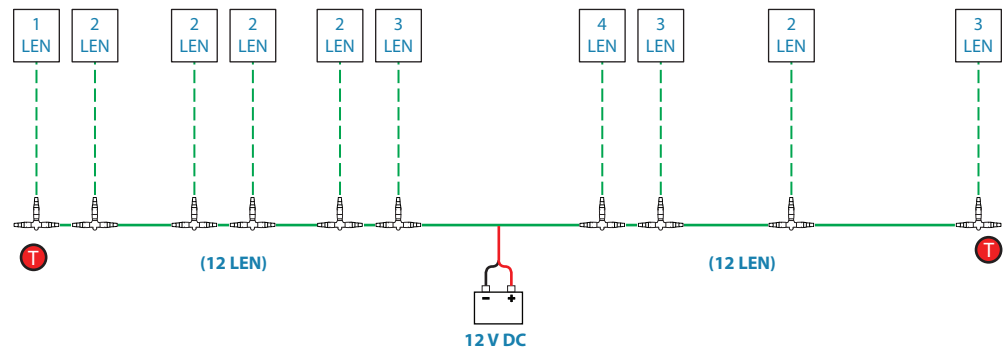

Powering drive units

AC70 computer requires separate power supply for drive units. Refer "Autopilot computers" on page 27.

Polarity protection

For supply to SI80 and AC70 boards, pay special attention to polarity protection.

The main supply fuse for these units is supplied loose in the bag with the cable plugs, and it should not be put in place before polarity is checked.

1. Connect the power wires, and verify that the green diode is lit
 - A red diode indicates wrong polarity, and the wires must be swapped
2. Switch off the power supply voltage and put the fuse into correct position

The illustration shows power terminal and diodes on the AC70 board. For location of terminals, fuse and diodes on the board, refer to the illustration inside the computer unit.

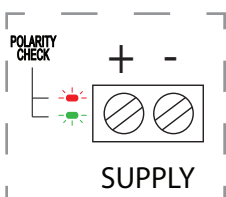

Powering the AP70 and AP80 control units

The AP70 and AP80 control units are powered directly from a 12 V DC or 24 V DC source. The units are protected against reverse polarity, under voltage and over voltage.

Power cable connector (female)

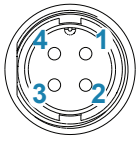

Key	Color	Description
1	Black	Battery (-)
2	Blue	Alarm/Active
3	Yellow	External command
4	Red	Battery (+), 12 - 24 V DC

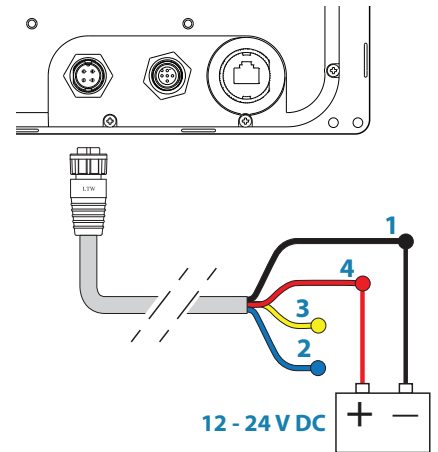

- **Note:** It is recommended to install an external on/off switch for power.
- **Note:** Do not connect the power cable to the same terminals as the start batteries, drive units, thruster or other high current products

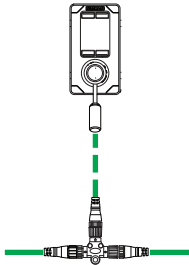

FU80, NF80 and QS80 Remote control units

FU80, NF80 and QS80 Remote control units connect to the CAN bus by drop cables and Micro-C T-joiners. The remotes are powered from the backbone.

For details see the separate manual for these remote units.

Steering levers

Connects to: AC70 board (in AC70 computer) or SI80 board (in SI80, AC80A, AC80S or AC85 Computer)

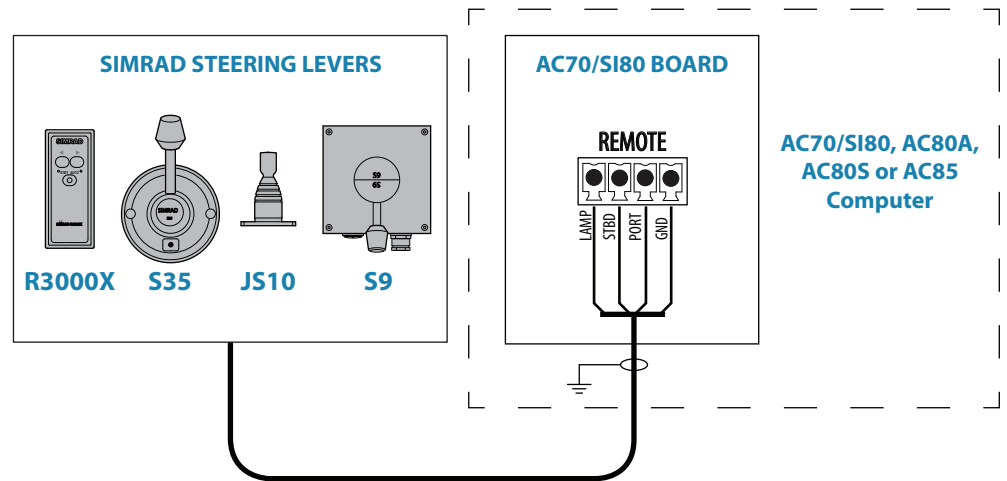

Wire color/Internal remote termination				AC70/SI80 board termination
S35	R3000X	JS10	S9	
Yellow	Yellow	N/C	N/C	Lamp
Brown/White	Green	Green	B2	STDB
Pink/Grey	Red	Red	B1	Port
Green	Blue	Blue	B3	GND

Interchange the Port and Stbd wires on the AC70/SI80 board if necessary to make the command from the keys/lever coincide with the direction of the rudder movement.

NMEA 2000 and SimNet devices

NMEA 2000 devices can be connected to the CAN bus providing they are NMEA 2000 certified, meet the CE, FCC regulations and do not exceed the load specification.

NMEA 2000 devices and SimNet devices with Micro-C connectors connects directly to the CAN bus backbone using drop cables and Micro-C T-joiners.

→ **Note:** It is recommended to use a gateway when connecting non-Simrad units to the CAN bus backbone.

Devices with SimNet connectors only must be connected using a SimNet to Micro-C adapter cable.

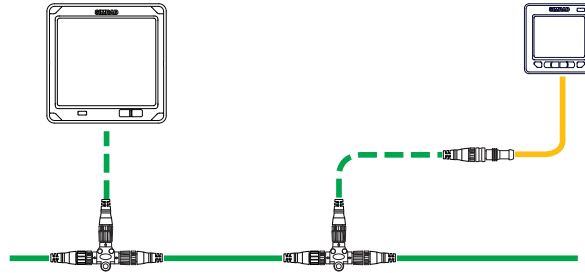

IEC61162-1/2 (NMEA 0183) devices

Connects to: AC70 (in AC70 or AC85 Computer) and SI80 board (in SI80, AC80A, AC80S or AC85 computer).

The AC70 board have 1 NMEA terminal, while the SI80 board includes 4 NMEA terminals.

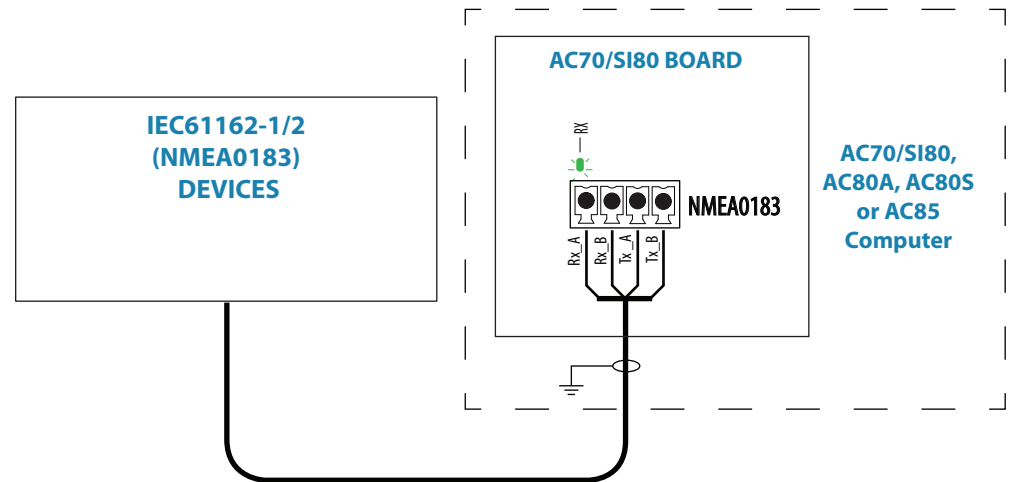

The green LED at each NMEA terminal is living when serial data is received.

The board uses the serial RS422 (IEC 61162-1/2) standard and can be configured in the software for different baud rates, up to 38.400 baud. Sentences output by the autopilot computer can be individually turned on or off.

Refer "Device list" on page 43 and "Supported data" on page 78

Autopilot computers

Grounding

The autopilot system has excellent radio frequency interference protection and all units use the autopilot computers as a common ground/shield connection. The units must therefore have a proper ground connection to the hull.

Termination, general

Power and signal cables connect with screw terminals or terminal blocks on the board inside the computer unit. Refer connection details on the following pages.

1. Insert the cable through an appropriate cable gland or slot
2. Strip of the cable insulation. Provide sufficient wire length so that the plug-in terminals can be easily connected and disconnected
3. Pull out each terminal blocks from the board before connecting the wires
4. Terminate the wires to the terminal blocks according to the terminal specification in the following pages
5. Connect the terminal blocks to the board
6. Crimp a Faston terminal to the screen and connect to the grounding plug-in terminal on the board, or on the grounding list
7. Secure the cables by using cable ties

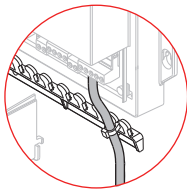
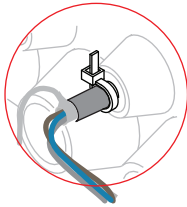

Connecting the computers to the CAN bus

AC70, SD80, AD80 and SI80 autopilot computers connect anywhere on the CAN bus back bone by using drop cables connected to a female connector on the Micro-C T-joiner.

AC80S, AC80A and AC85 autopilot computers includes a terminator, and should be connected at the end of the CAN bus back bone. The drop cable is connected to the male connector on the Micro-C T-joiner, and to the SimNet terminal on the computer board.

The drop cable is supplied with the autopilot computer.

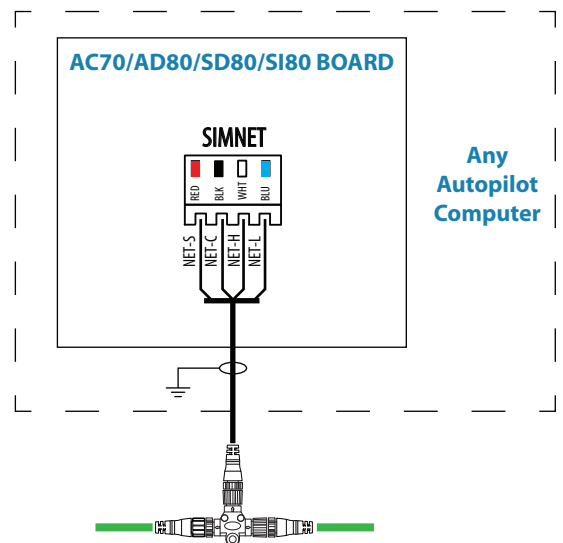

Mounting and Interconnecting the boards in the AC85 Computer

The AC85 computer is delivered with one SI80 board. The SI80 board is not mounted from factory. Optional boards are ordered separately.

The boards should be located as shown on the illustration, and secured to the computer base with the supplied screws and washers.

A detailed mounting description is included with the AC85 computer. The document can also be downloaded from our web site.

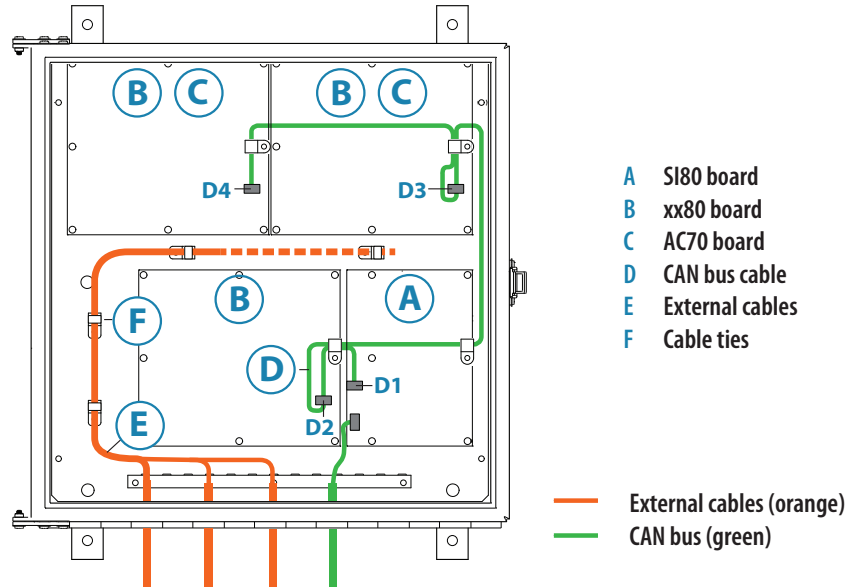

Drive units

Connecting diagrams for the different drive units are found on the following pages.

Installation instructions for the drive units are found in the manuals for the individual units.

Reversible pump

Connects to: AC70 board (in AC70 or AC85 Computer).

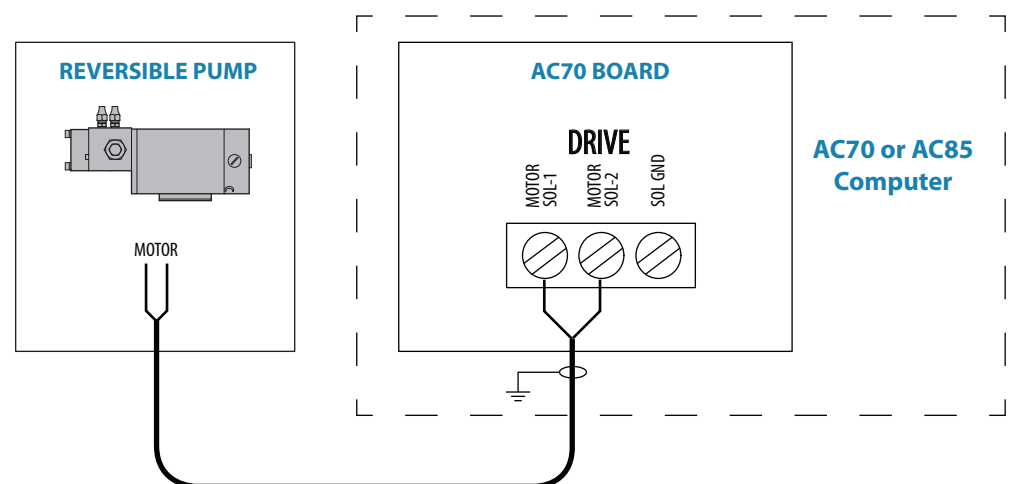

Rotary drive

Connects to: AC70 board (in AC70 or AC85 Computer).

Rotary drive (reversible motor with clutch) is normally used for mechanical connection to Voith Schneider drive system or helm unit on sailing vessels.

The rotary drive need connection to the Engage terminal for clutch operation.

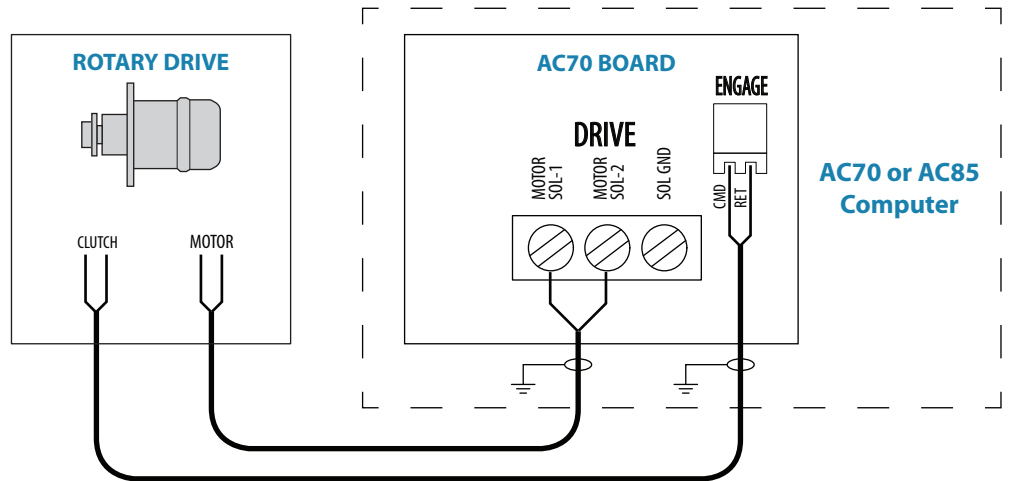

Solenoid valves, 12 V or 24 V DC

The following figures described operation of 12 V or 24 V solenoids.

For solenoids with higher voltage (110/220 V AC or DC), use external relays/solid state relays.

Internally powered Solenoids

Connects to: AC70 board (in AC70 or AC85 Computer).

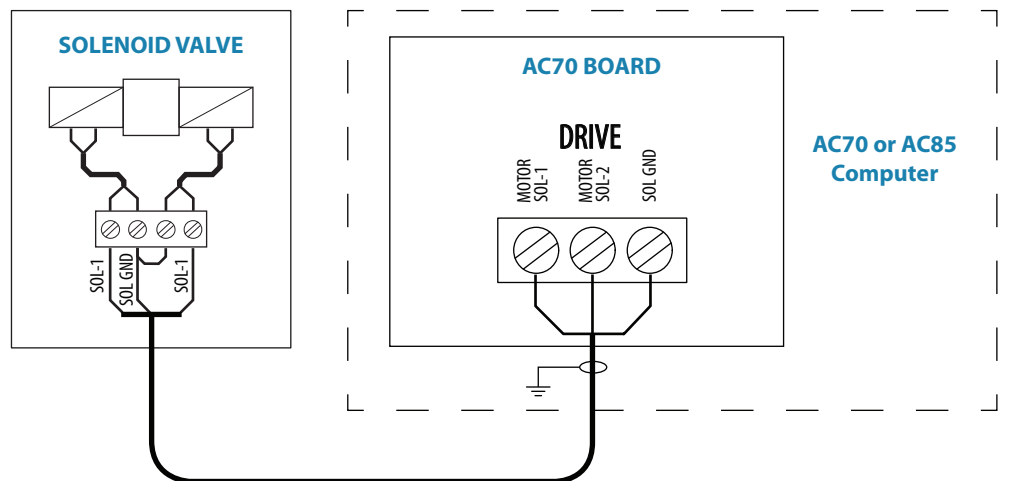

Externally powered solenoids, common negative

Connects to: SD80 board (in SD80, AC80S or AC85 Computer).

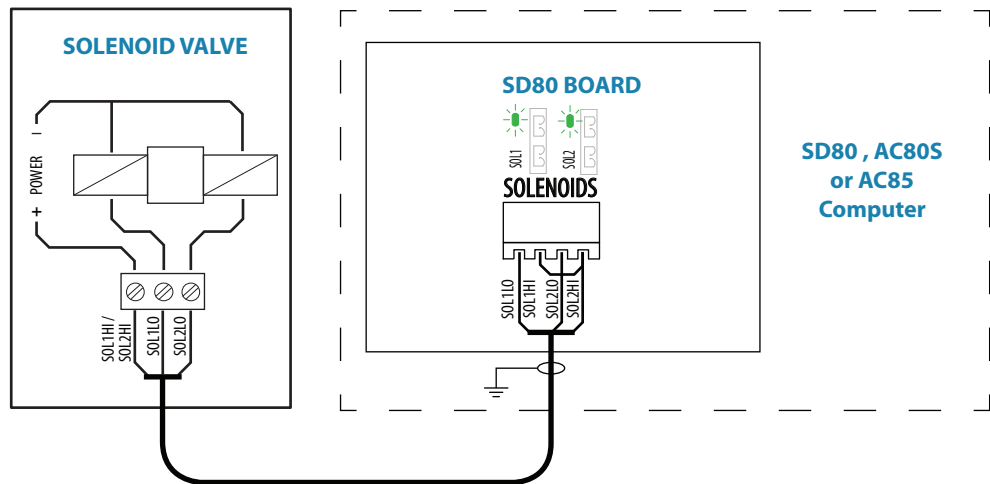

Externally powered solenoids, common positive

Connects to: SD80 board (in SD80, AC80S or AC85 Computer).

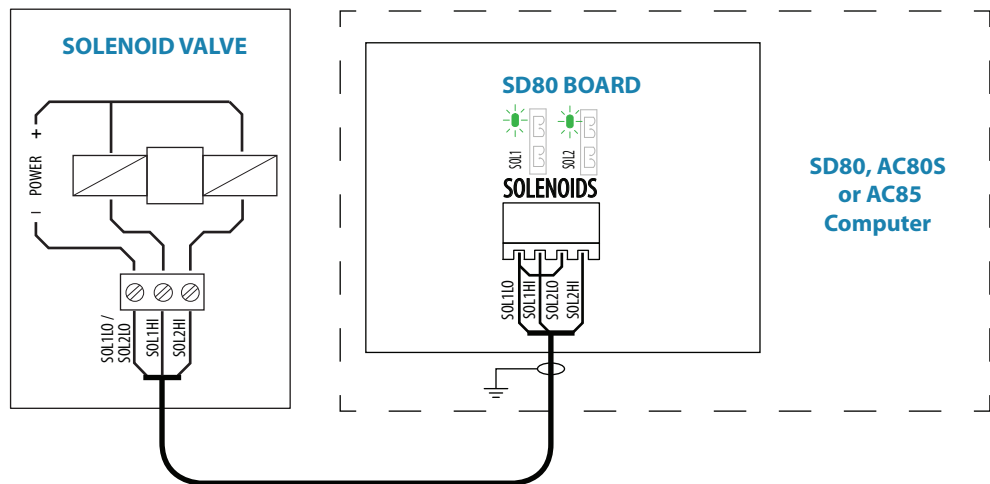

Analog steering gear

Connects to: AC80 board (in AD80, AC80A or AC85 Computer).

The AD80 board provides analog control of rudder(s) and thrusters in an AP70 and AP80 system by either continuous voltage or current signal.

The **UI_CTRL** DIP switch is used to voltage control line.

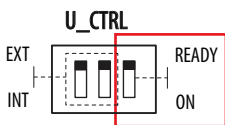

- Set to **READY**, the voltage control line will be broken by a solid state relay contact when the autopilot is not ready for steering (Power off and serious error situations)
- Set to **ON** the line will always be connected

Additional switch settings for the alternative steering gear control alternatives are included in next the sections.

Internal voltage control

A nominal 0±10 V DC control signal is available for control. This voltage is galvanic isolated from the operating voltage for the autopilot. Rudder zero voltage and control range can be adjusted in the Dockside Drive setup. See “Rudder feedback/tunnel thruster feedback calibration” on page 51 .

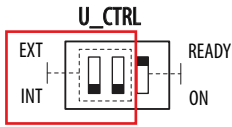

For Analog output, internal voltage, the switch must be set to **INT**.

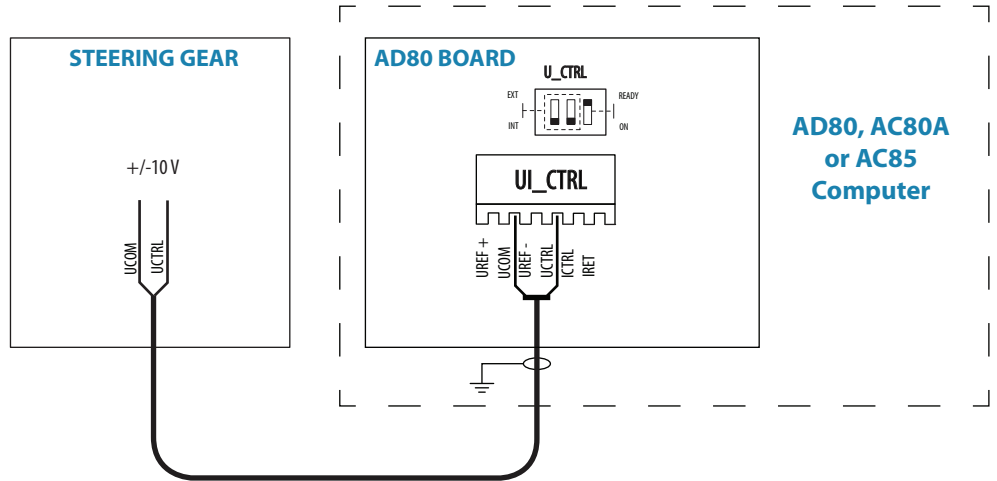

Voltage control with external reference, +/- variable

Available control range will be +/- V signal, appr. 45% of external reference voltage. Zero setting and control range output at **U_CTRL** can be adjusted in dockside setup.

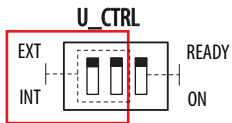

For Analog output, external voltage, the switch must be set to **EXT**.

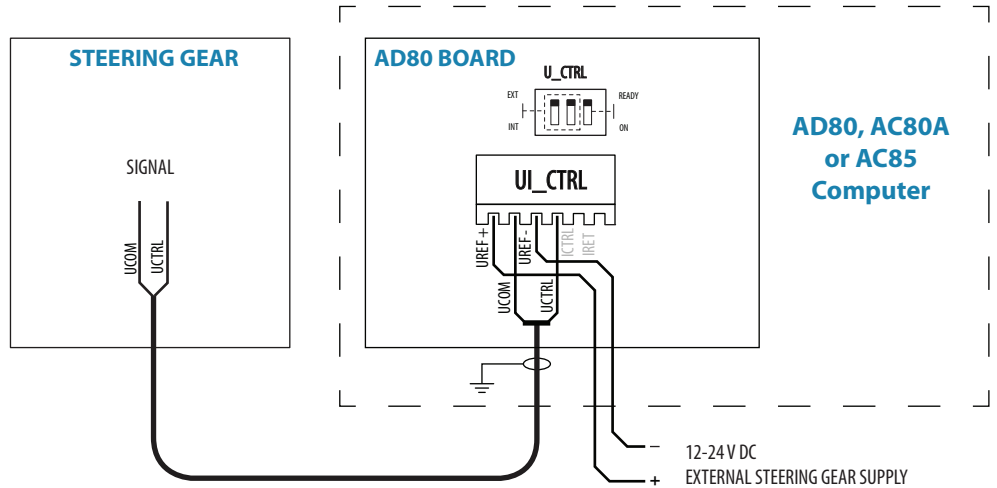

Voltage control with external reference, positive variable

Normally used to control proportional valves with 12 V and 24 V power.

Available control range will be from 5-95% of external voltage. Control signal will be positive variable relative the external reference voltage minus.

Zero output = External power/2.

Zero setting and control range output at **U_CTRL** can be adjusted in dockside setup. See "Rudder feedback/tunnel thruster feedback calibration" on page 51 .

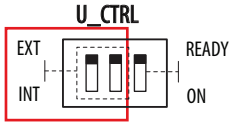

For Analog output, external voltage, the switch must be set to **EXT**.

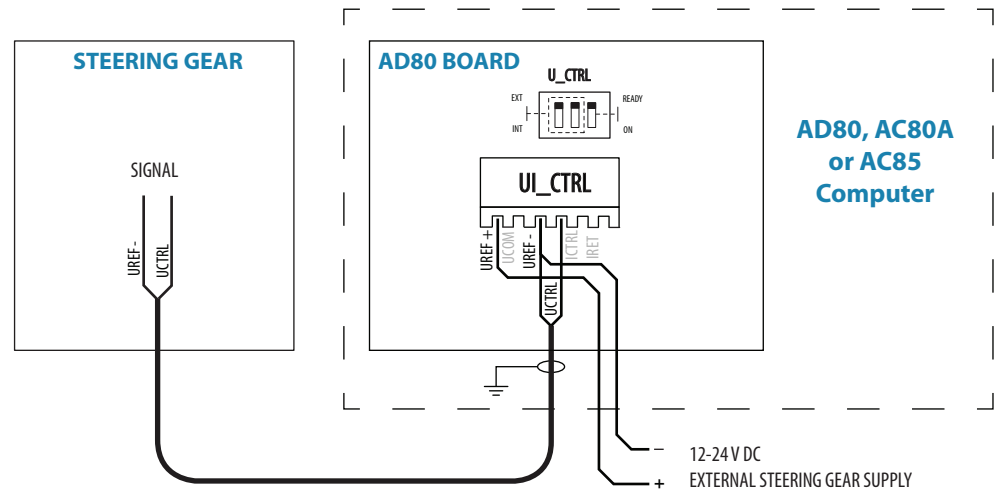

Analog output, current

A 4-20 mA control signal is available. Rudder zero current and control range can be adjusted in the Dockside setup (ref. page 55).

Rudder zero current and control range can be adjusted in dockside setup. See "Rudder feedback/tunnel thruster feedback calibration" on page 51.

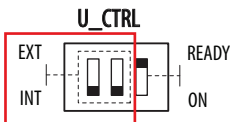

For Analog output, current, the switch must be set to **INT**.

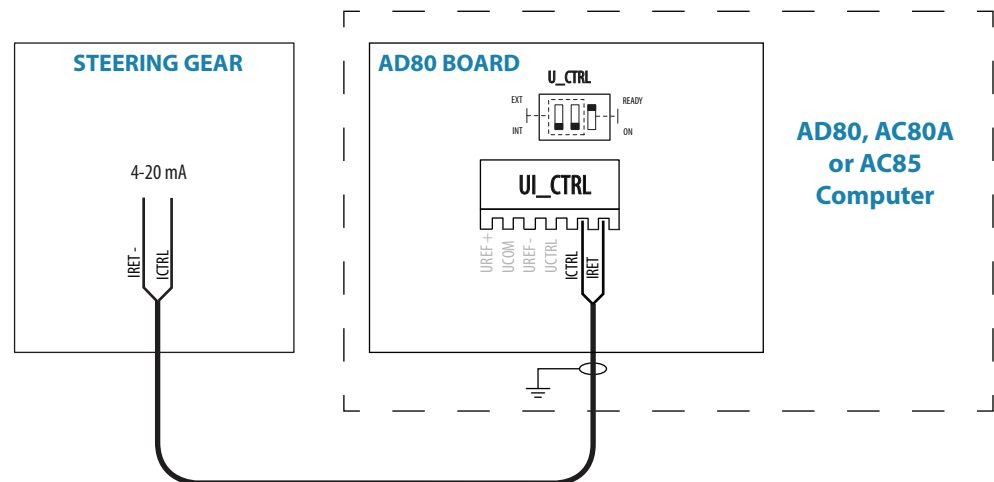

Rudder feedback

RF300, RF45X

Connects to: AC70 board (in AC70 or AC85 Computer), SD80 board (in SD80, AC80S or AC85 Computer) or AD80 board (in AD80, AC80S or AC85 Computer).

RF300 = White and Brown wires

RF45X = Red and Blue wires

→ **Note:** Polarity independent.

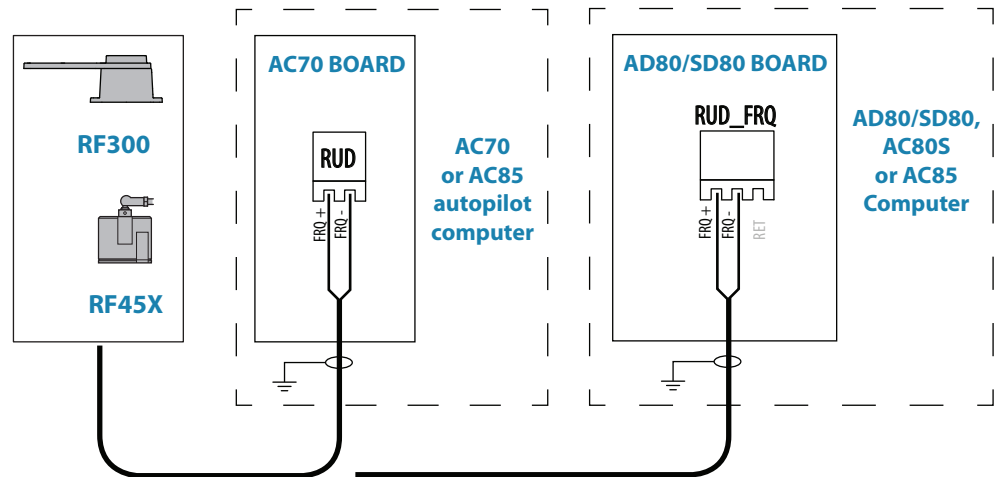

RF14XU

Connects to: SD80 board (in SD80, AC80S or AC85 Computer) or AD80 board (in AD80, AC80S or AC85 Computer).

The cables are carried through cable glands. If required, to avoid any mechanical damage, the cables should be run in a conduit between the rudder feedback unit and the autopilot computer.

The cable screen must be connected to the internal ground terminal.

The feedback unit has an external ground terminal and must have a proper ground connection to the hull. The grounding wire should be as short as possible and at least 10 mm wide.

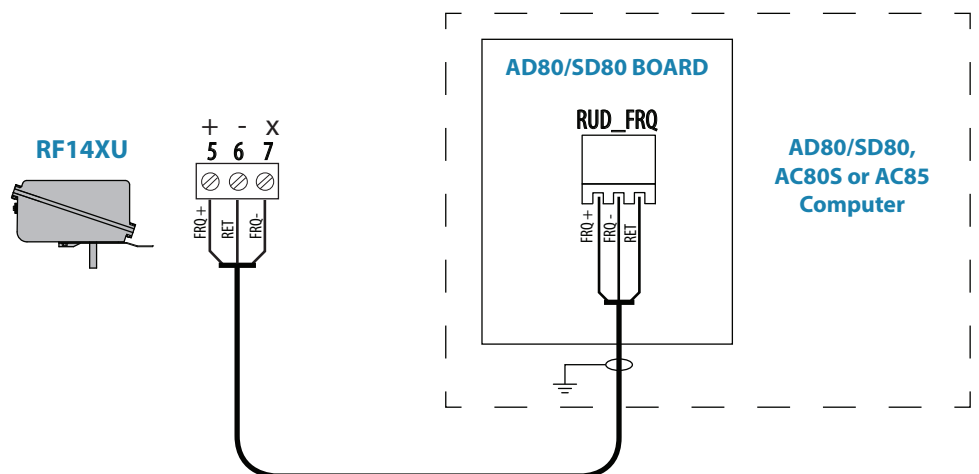

Current feedback input

Connects to: SD80 board (in SD80, AC80S or AC85 Computer) or AD80 board (in AD80, AC80S or AC85 Computer).

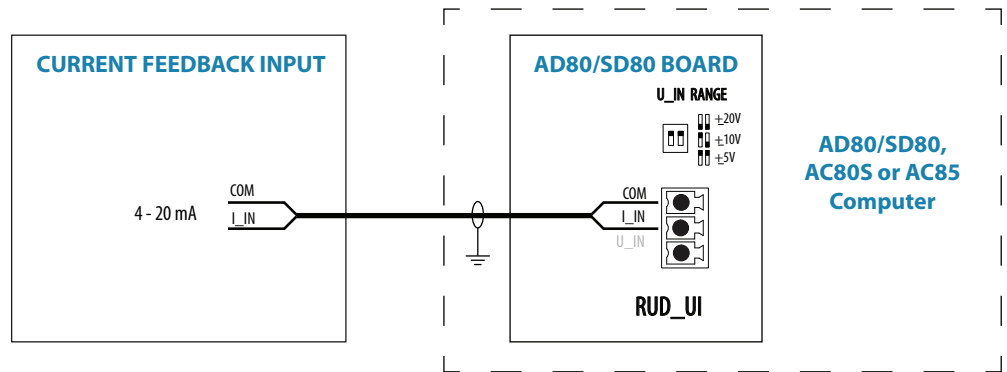

External feedback pot.meter input

Connects to: SD80 board (in SD80, AC80S or AC85 Computer) or AD80 board (in AD80, AC80S or AC85 Computer).

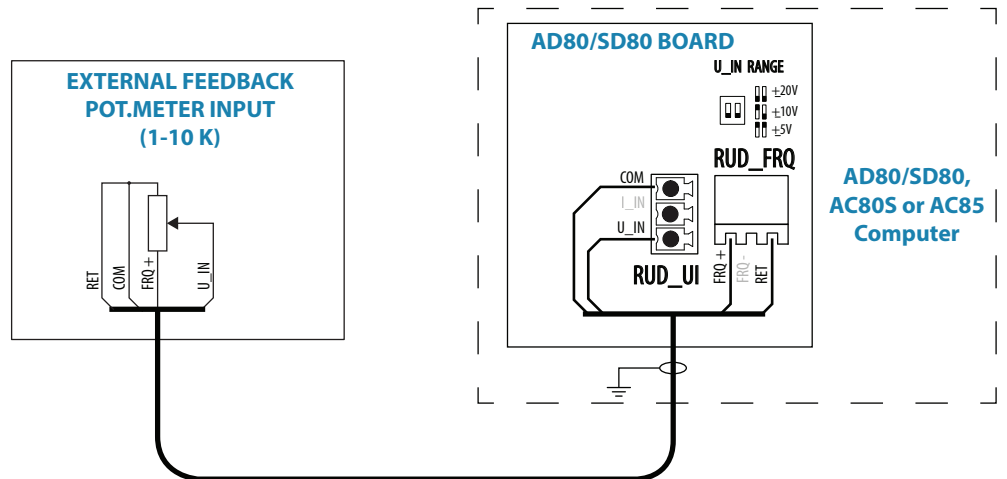

U_IN RANGE

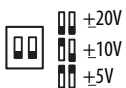

The DIP switch must be set to +/- 20 V.

External voltage feedback input

Connects to: SD80 board (in SD80, AC80S or AC85 Computer) or AD80 board (in AD80, AC80S or AC85 Computer).

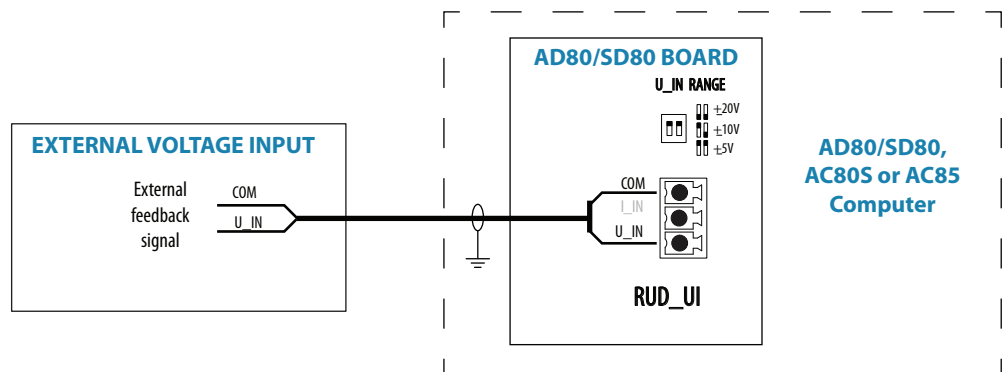

U_IN RANGE



The DIP switch must be set to match range for analog voltage input signal.

Alarm interface

External alarm

An external alarm can be connected to the autopilot control head. The alarm signal have an open contact for an alarm buzzer or an external alarm relay as illustrated below. The alarm voltage is the same as the main supply voltage. The maximum load on the external alarm output is 0.75 Amp.

Alarms are configured globally in the system, i.e. they can be configured on one unit and seen, heard and acknowledged from all control units.

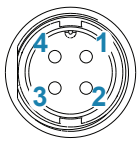
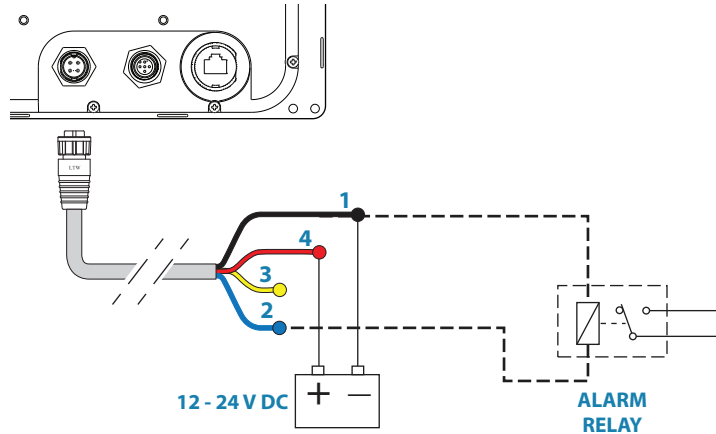

Key	Color	Description
1	Black	Battery (-)
2	Blue	Alarm/Active
3	Yellow	External command
4	Red	Battery (+), 12 - 24V DC

External alarm setup

The siren must be enabled in order for the unit to drive the external alarm when an alarm condition arises.

Refer the alarm description in the separate AP70/AP80 Operator manual.

External Take command

An external take command signal can be used to take command on a control unit.

The function is identical to a short press on the **CMD** key on the AP70 and AP80 control unit.

In an open system (no command transfer restrictions) you will get immediate control from the control unit requesting command.

In a multi-station system with active lock function, the command request must be confirmed on the active control unit.

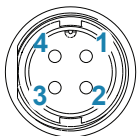
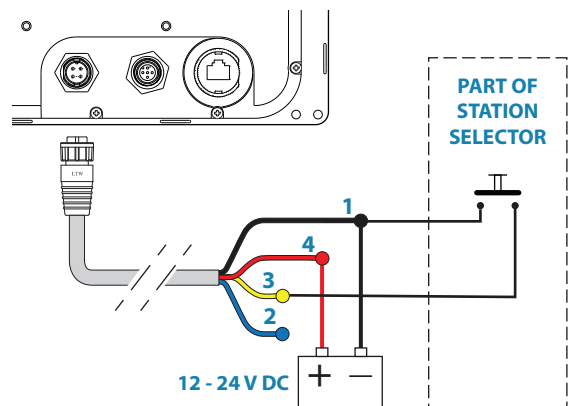

Key	Color	Description
1	Black	Battery (-)
2	Blue	Alarm/Active
3	Yellow	External command
4	Red	Battery (+), 12 - 24V DC

External I/O

Handshake

Connects to: SD80 board (in SD80, AC80S or AC85 Computer) or AD80 board (in AD80, AC80S or AC85 Computer).

The SD80 and AD80 boards have two identical galvanic isolated handshake digital I/O ports that can be sw configured for various applications like interface to steering gear control, hand steering override, watch alarm, direct i/o type central alarm panel, pulse log input and pendulum ferry function.

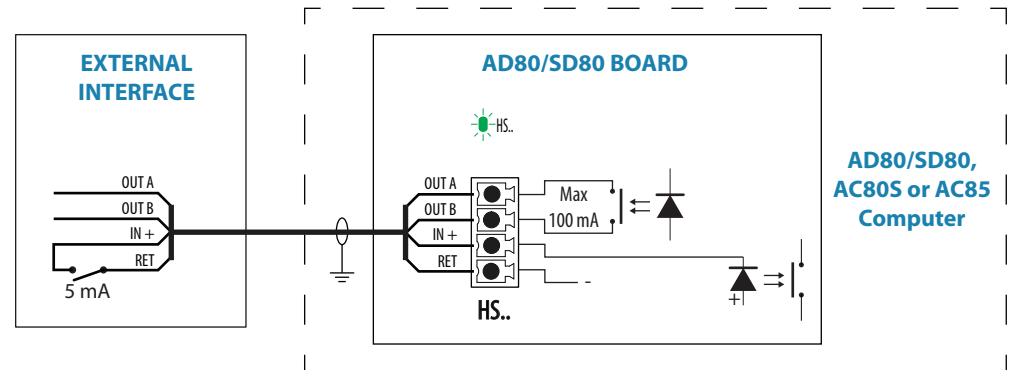

The LED is green when handshake output is on.

→ **Note:** The Handshake must be defined as described in “Dockside - Drive system” on page 46.

Central alarm panel with direct I/O interface

Connects to: AP70/AP80 Control unit, and AD80 board or SD80 board.

The interfacing described below applies for central alarm panels that use direct lines for alarm, mute and acknowledge. For alarm panel using serial interface, refer to “IEC61162-1/2 (NMEA 0183) devices” on page 26.

The autopilot system will have two cable connections to a Central Alarm panel;

- one from the autopilot control unit
- one from the autopilot computer

From the autopilot control unit we are using the same two wires (red and blue) as for external alarm relay connection.

Under normal operation you will see 12/24 V between these two wires. In an alarm situation, or when power is lost, you will see no voltage.

From the autopilot computer we are using the handshake connection on the SD80 or AD80 board for alarm mute and acknowledge.

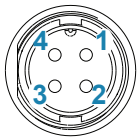
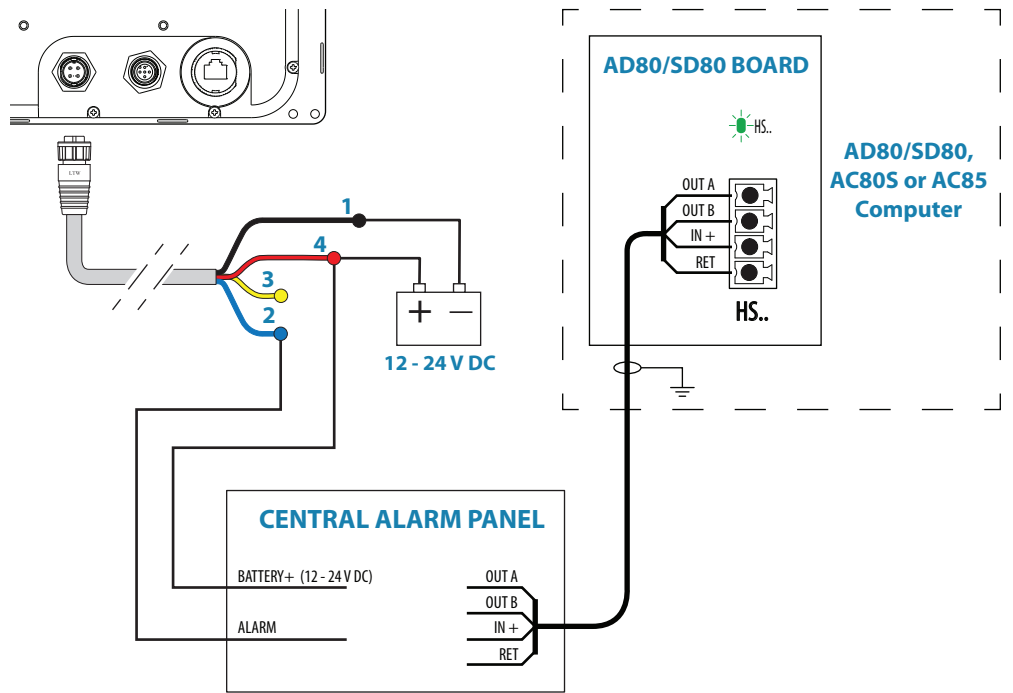

Key	Color	Description
1	Black	Battery (-)
2	Blue	Alarm/Active
3	Yellow	External command
4	Red	Battery (+), 12 - 24 V DC

Engage signal

Connects to: AC70 board (in AC70 or AC85 Computer) or SD80 board (in SD80, AC80S or AC85 Computer).

Engage is primarily for operating bypass or dual speed valve, clutch etc for hydraulic or mechanical drive units. The output can be sw configured for activating in all steering modes except STBY or in AUTO modes only.

For AC70 the drive voltage is internally supplied and the voltage level follows the nominal drive voltage set in sw configuration of the AC70 drive.

For SD80 the drive voltage is galvanic isolated and has to be externally supplied. The output can also be sw configured for proportional valve control.

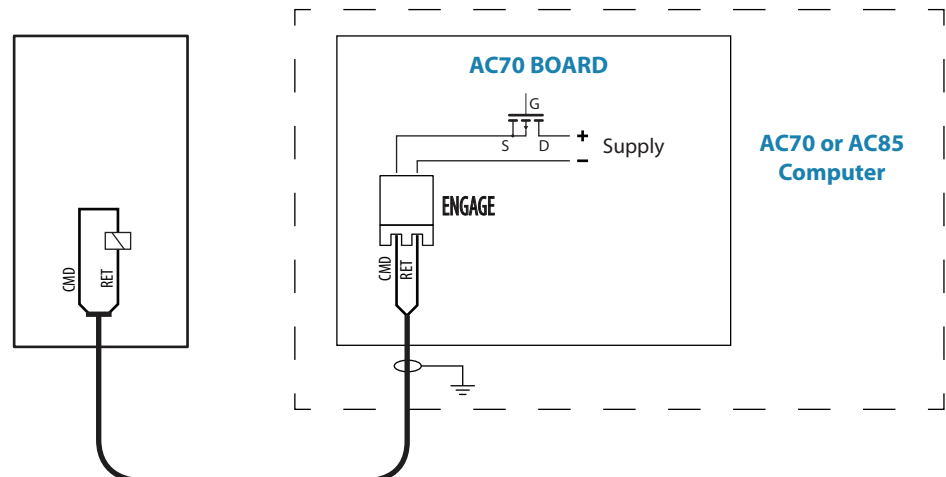

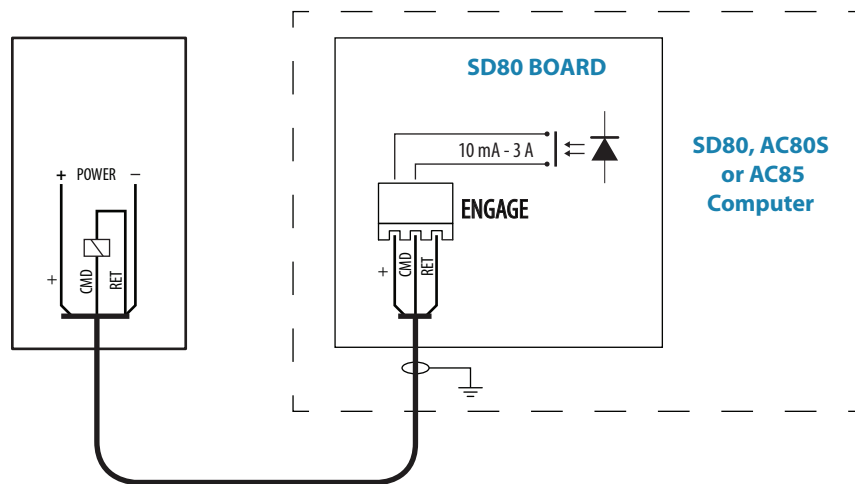

Ready signal

Connects to: SD80 board (in SD80, AC80S or AC85 Computer) or AD80 board (in AD80, AC80A or AC85 Computer).

The Ready signal is given when the autopilot system is operative for taking control. In case of serious software or hardware failure and when the system is turned off, the signal line will open. Some steering gears will use the signal to block rudder/thruster command in case of a serious autopilot failure.

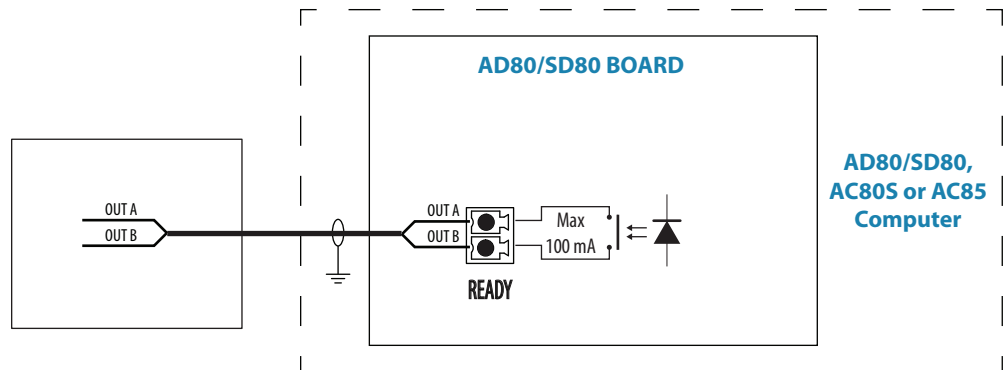

External system selection

Connects to: SD80 board (in SD80, AC80S or AC85 Computer) or AD80 board (in AD80, AC80A or AC85 Computer).



The system select (Sys sel) input signal can be used to alternate between the vessel's own manual steering system and the autopilot system from an external system selector. Refer to IMO resolution MSC 64, sec. 4.

A closing contact between the **SYSEL** and **RET** terminals will disengage the autopilot from the vessel's steering system. The disengaged status will shown on the autopilot display.

When the contact is re-opened, the autopilot will go to **AUTO** mode with current compass heading as set heading.

→ **Note:** The autopilot will always return to **AUTO** mode, even if it was in **NoDrift** or **NAV** mode.

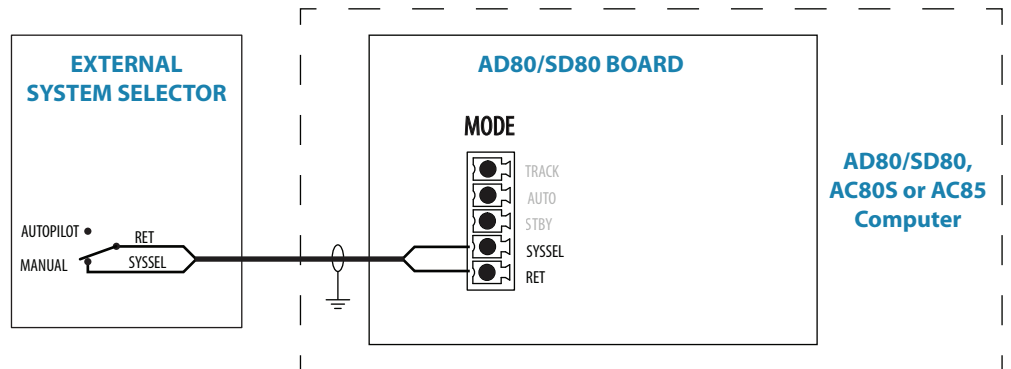

External mode selection - pulse

Connects to: SD80 board (in SD80 or AC85 Computer) or AD80 board (in AD80A or AC85 Computer).

External mode selection can be arranged with push buttons as shown in the figure below.

The two push buttons will have similar function as the **STBY** and **AUTO** keys on the AP70 and AP80 control units.

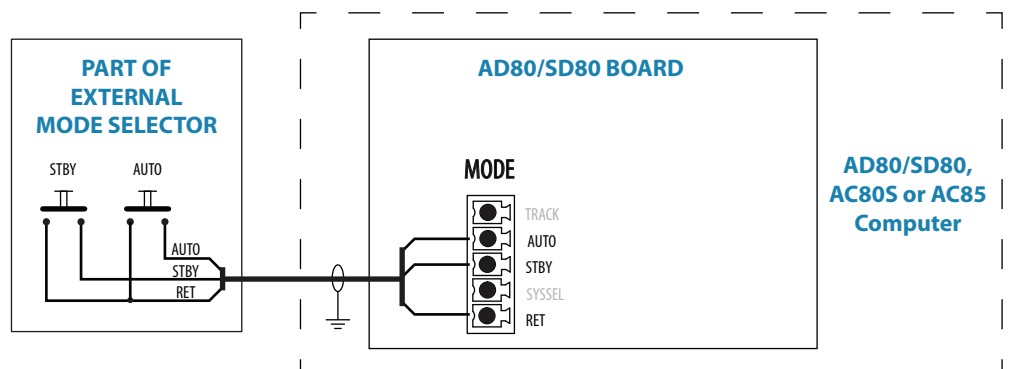

ECDIS system

Connect the NMEA 0183 serial line from the ECDIS to Ch. 3 NMEA terminal on the SI80 board.

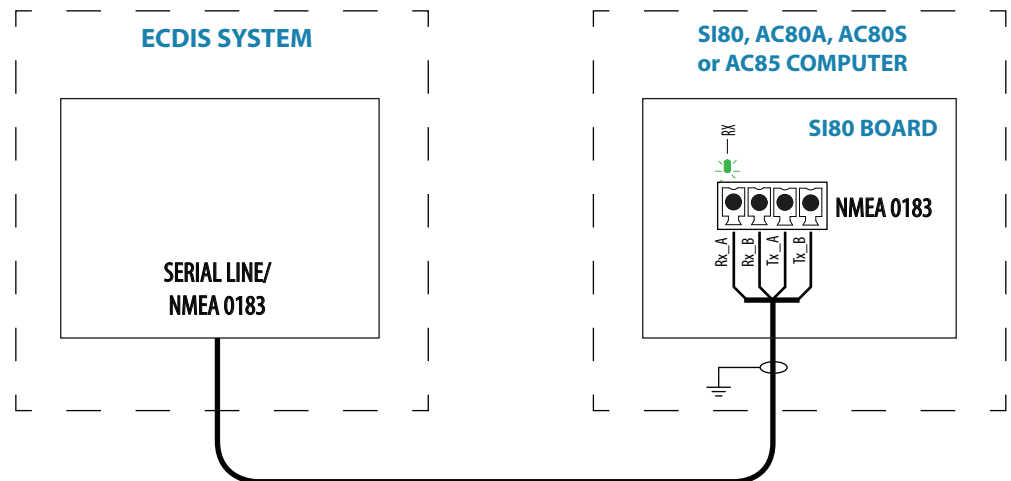

The green LED at the NMEA terminal is living when serial data is received.

Backup navigator alarm

A backup navigator alarm is available when the AP80 is connected to an ECDIS in a Track system.

If an alarm is not acknowledged within the specified timeframe e.g. “wheelover”, “end of route” or “track control stopped”, a backup navigator alarm can be activated to notify bridge officer off duty. The backup navigator alarm can only be acknowledged from AP80.

To enable this feature, the autopilot system provides a configurable handshake port on SD80 or AD80 that can be connected to an external alarm panel or loudspeaker.

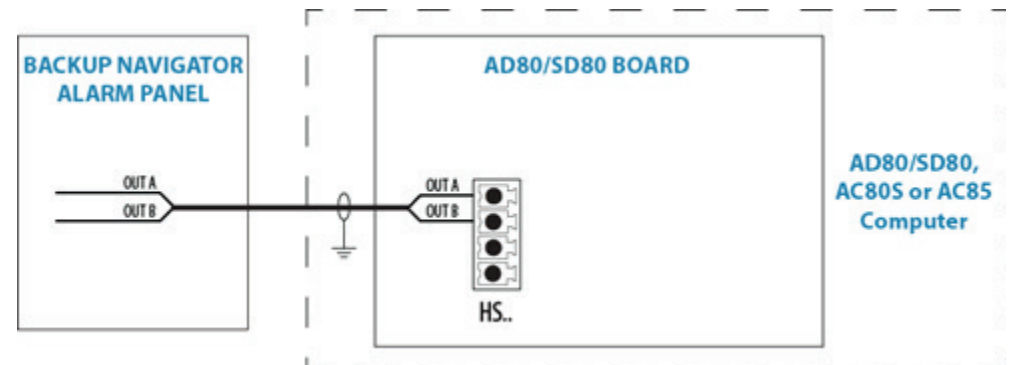

4

System configuration





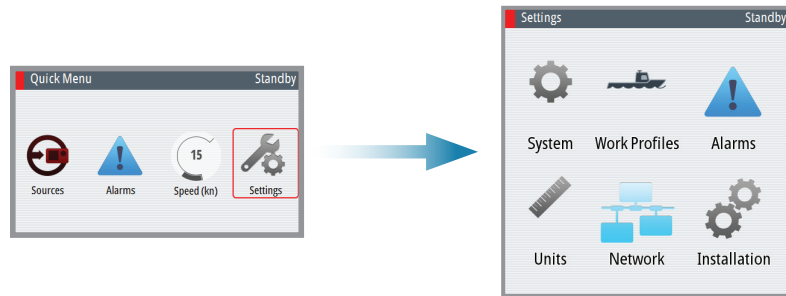

General

When the autopilot installation is completed, the system must be configured and the commissioning procedures performed. Failure in setting up the autopilot correctly may prohibit the autopilot from functioning properly.

The settings dialog and submenus

The system configuration settings are logically grouped in the Settings dialog, and each group is presented with an icon. This dialog is accessed by pressing the Settings icon available in all mode specific menus, or by double clicking the **MENU** key.



Icon	Description	Refer
	System settings. These settings have no affect on autopilot performance	
	Work profile settings	AP70/AP80 Operator manual
	Active alarms, alarm history and alarm settings	
	Units of measure used on display, in dialogs and menus.	-
	Network sources setup	"Network settings" on page 42
	Installation setup. The pilot must be in Standby mode to access these settings	"Installation settings" on page 46

Turning on for the first time

Before attempting to turn on the autopilot and perform an Installation Set-up, the hardware installation and electrical installation must be completed and performed in accordance with the installation instructions

The first time the autopilot system is started and after a factory reset, you will be guided through a set of initial settings. On additional control heads, acknowledge language selection and cancel all other setup requests.

If the settings are not completed, you can configure the autopilot system manually as described in the following sections.

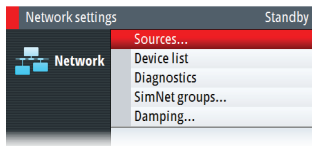

Network settings

Setup and selection of sources are done from the Network menu.

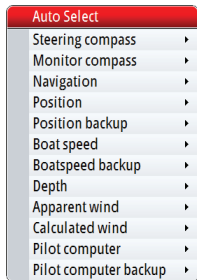

Selecting data sources

A data source can be a sensor or a device connected to the network, providing data to other devices. Data can be of different type such as compass data, apparent wind data, calculated wind data, depth data, etc.

Source selection is required on initial start up of the system, if any part of the CAN bus network has been changed or replaced, or if an alternative source is made available for a given data type and this source has not been selected automatically.

At the first time turn on of a group of SimNet interconnected products, data sources are automatically selected from an internal SimNet priority list. If a data source is connected to SimNet after the first time turn on, this will be identified and automatically selected if no other data source already is selected for the given data type.

You can let the system automatically select your sources, or set up each source manually as described below.

Auto select

The Auto Select option will look for all SimNet sources connected to the network. If more than one source is available for each data type, the system will automatically select from an internal priority list.

The Auto select function is mainly for situations where the automatic source selection needs to be updated because a selected data source is not supplying data or has been physically replaced with another one. The update secures that the existing source selections are valid and maintained. Missing sources are either automatically exchanged with an alternative source from the list of available sources for the given data type, or the replacing source is selected.

Manual source selection

You can manually select the preferred source. This is useful if you have more than one of the same type of device on the network.

Available sources are listed as shown in the example below. You select active source by ticking the preferred unit.

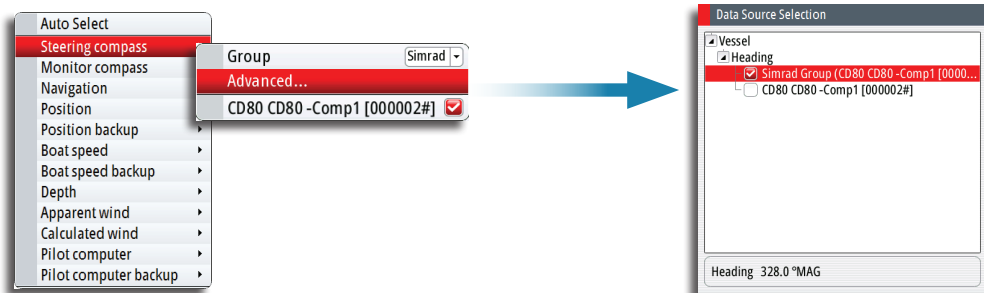

Group selection

The autopilot system can use data sources that all other products on the network use, or select individual sources for the autopilot system.

If the group is set to Simrad, any changes to a source will also affect other systems on the network.

If the group is None, the selected source will be used for the autopilot system only.

In the example below the steering compass is common for all systems on the network.

Advanced selection

Allows the advanced selection of sources available on the network.

Device list

From the device list you can:

- list all of the active SimNet and NMEA 2000 devices on the network, showing model description and serial number. Devices can be sorted by model ID or by serial number
- display information relating to a device such as, name, manufacturer, software version, instance, status
- give the device a logical name relevant to the user
- see data coming from the device
- get access to configuration page for the device

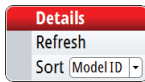

- Press the **MENU** key to sort the device list
- Press the **MENU** key, the **STBD** key or the rotary knob to see selected device details.

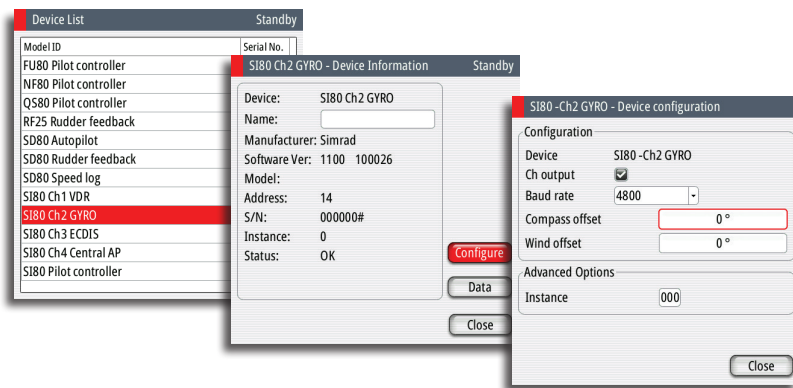

→ **Note:** The graphics show gyro input on an SI80 board. Device details and options depends on data type.

Diagnostics

The diagnostic page shows details for the NMEA 2000/CAN bus network.

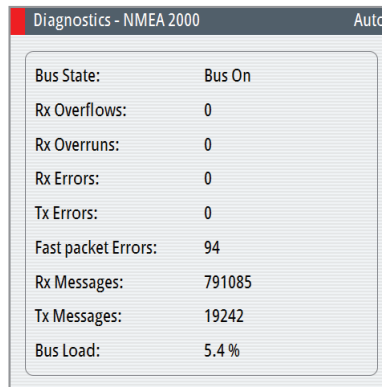

Option	Description
Bus State	Indicates if network backbone is operating. Check power: Check termination
Rx Overflows	Value greater than 0 could indicate the software is very busy and unable to keep up with incoming messages.
Rx Overruns	
Rx Errors	CAN interface error counters. Count up when there are errors on the CAN bus, and down when things are ok. Should normally be 0. Goes bus off when 255 is reached. Check same things as for Bus state if greater than 0 observed
Tx Errors	
Fast packet Errors:	Detected errors since power up. Check the network if this is continually increasing.

Option	Description
Rx Messages	A count since power up of messages received / transmitted.
Tx Messages	
Bus Load	Real time bus load in percentage of max capacity

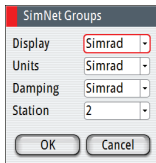

SimNet groups

The SimNet Group function is used to control parameter settings, either globally or in groups of units. The function is used on larger vessels where several SimNet units are connected via the network. By assigning several units to the same group, a parameter update on one unit will have the same effect on the rest of the group members.

The illustration below shows a two station installation. Units in the Remote Station have their backlight and damping settings in different SimNet Groups from the units on the Main Bridge. If the back light is adjusted on a display on the Main Bridge, it will change on all displays on the Main Bridge. It will not change the light settings in the Remote Station. If the damping is adjusted on the AP80 control unit, this will not affect damping on the NSE unit in the remote station.

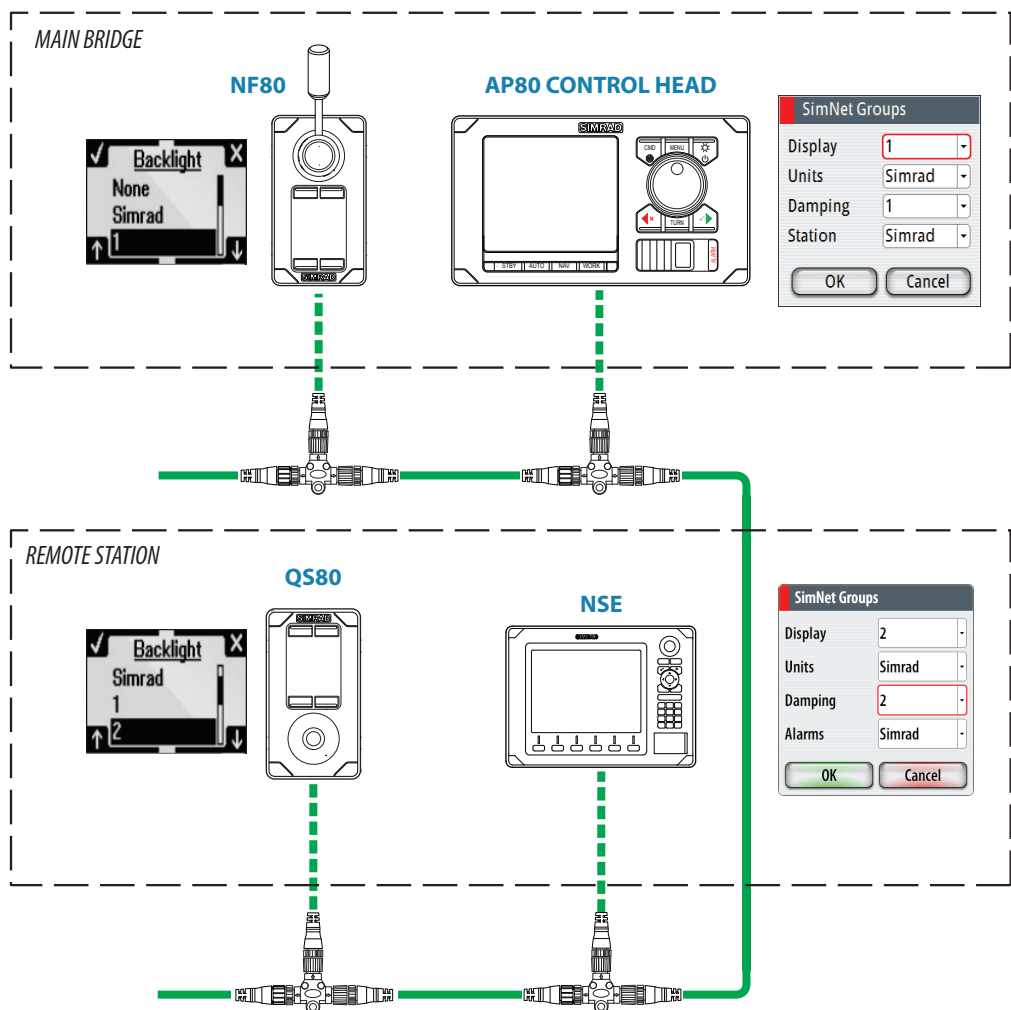

Master systems

The international standard for heading control systems (ISO 11674/ISO 16329) requires controlled command transfer when remote stations are provided. The delegation of control to the remote station and the return of control shall be incorporated in the autopilot system, and shall avoid unintended operation from a remote station.

To fulfill this requirement the AP70/AP80 system includes a Master function. This is used in larger Wheelmarked systems where you permanently want to control command transfer to remote stations.

In a Master system, one steering station is defined as the Master station. There can be several



control units in a master station, but only one of them can be set as the Master unit.

All units included in the master station will be unlocked, and command transfer within the master group will be as in an open system.

Units not included in the master station will be locked. It is not possible to take command from units outside the master station unless the master control unit opens for this. All units outside the master station will have a lock symbol.

In the illustration below the main bridge is defined as master station. One QS80, one AP80 control unit and one AP70 control unit are included in the master station. The AP80 control unit is defined as the Master unit.

The illustration includes SimNet group settings for each unit, showing how the units are defined as part of different SimNet stations.

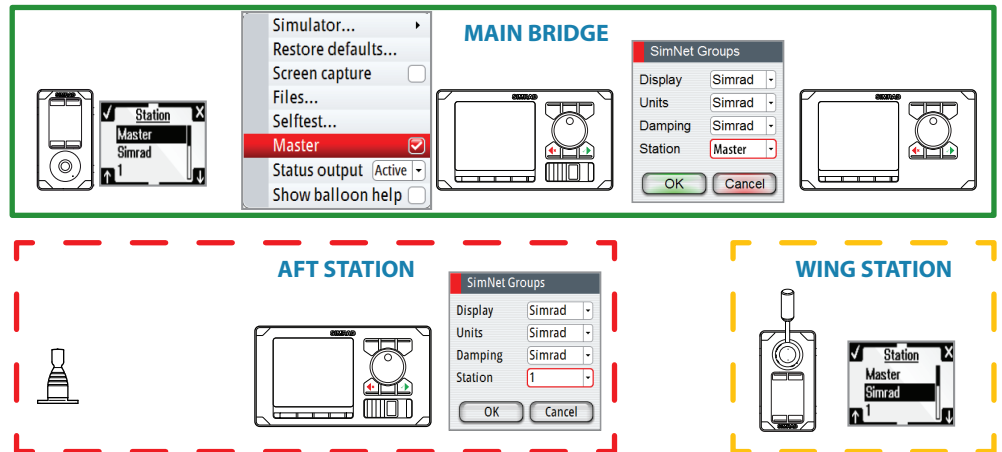

Defining a Master system

A master station is usually defined and units assigned to the master station during system setup.

➔ **Note:** When a SimNet group Station is set to Master, one control unit in this steering station has to be defined as the Master unit as shown below.

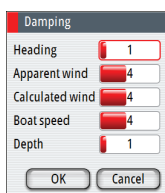
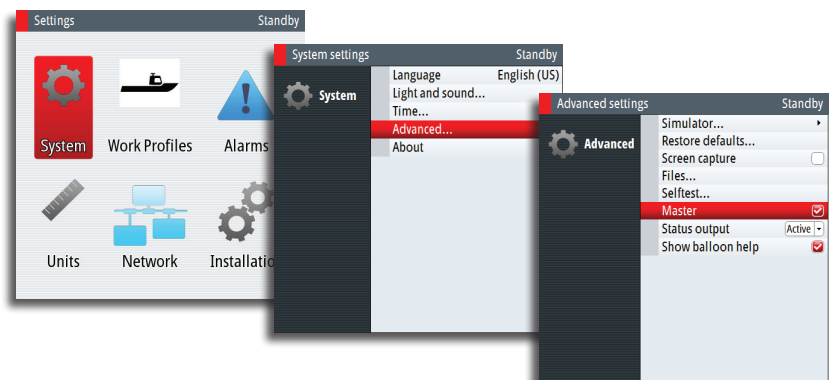
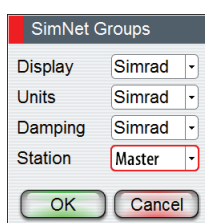

Damping

Controls how quickly the display updates values from sensors.

Increasing the damping applies more averaging or smoothing of the data update rate on the display.

Damping settings are applied to SimNet units belonging to particular damping SimNet Groups.

➔ **Note:** If the damping factor for heading is high, the captured heading might differ from the heading read on the display when using the heading capture function.

Installation settings

The installation setup includes dockside and seatrial configuration of drives, together with compass calibration.

When the autopilot is delivered from factory AND ANY TIME AFTER AN AUTOPILOT RESET HAS BEEN PERFORMED, the installation settings are all reset to factory preset (default) values. A notification will be displayed, and a complete setup has to be made.

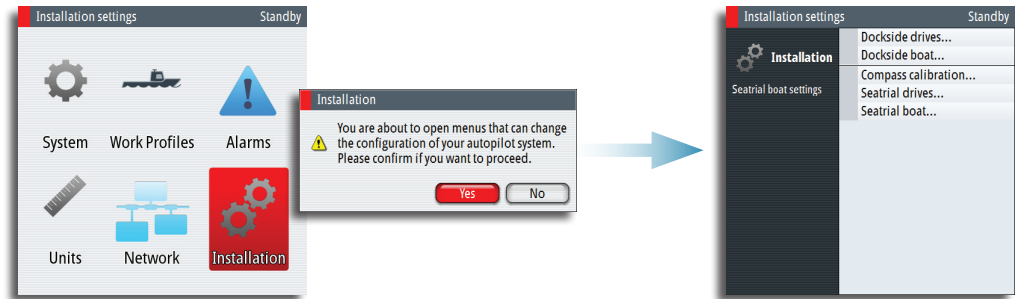

→ **Note:** The Installation settings can only be accessed in **STBY** mode.

⚠ Warning: The installation settings must be performed as part of the commissioning of the autopilot system. Failure to do so correctly may prohibit the autopilot from functioning properly!

→ **Note:** The seatrial settings are dependent on successful completion of the dockside settings.

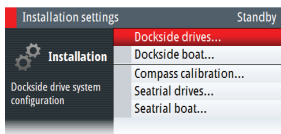

Dockside - Drive system

Drive units must be configured and calibrated before they can be used.

The drive system configuration dialog lists all drive units available on the network. The details field includes drive type, serial number and source name.

When the drive configuration is completed this is indicated with a tick after the drive name. The dialog will not illustrate drive type and location before the drive location and type is defined.

The following symbols are used to illustrate drive type:

	Tunnel thruster
	Azimuth
	Voith Schneider
	Rudder
	WaterJet

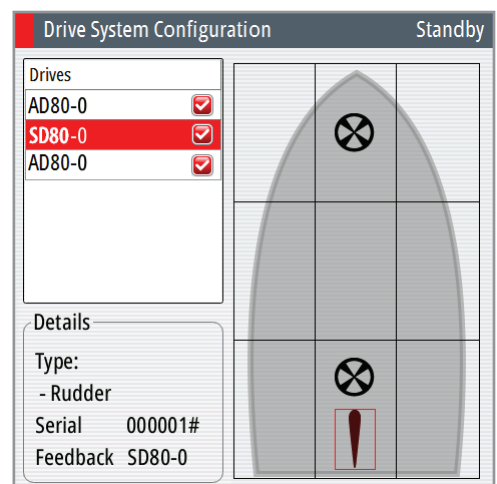

The figure shows a completed commissioning for a vessel with one rudder driven by an SD80 board, one solenoid operated tunnel thruster and one analog tunnel thruster operated by two different AD80 boards.

Configuring the drive system

The drive system configuration is accessed from the drive system configuration dialog.

1. Select the drive to be configured, and press the rotary knob or the **MENU** key to proceed to the device information dialog

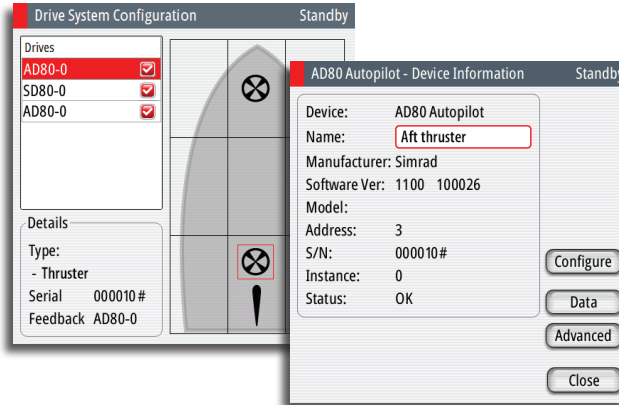

2. Enter a descriptive name for the device (e.g. Aft thruster)
 - If two identical boards are used, they are identified by the serial number. This number is found in the device information dialog on a tag on the SimNet plug on the board

→ **Note:** The label below is an example only and varies with board type.

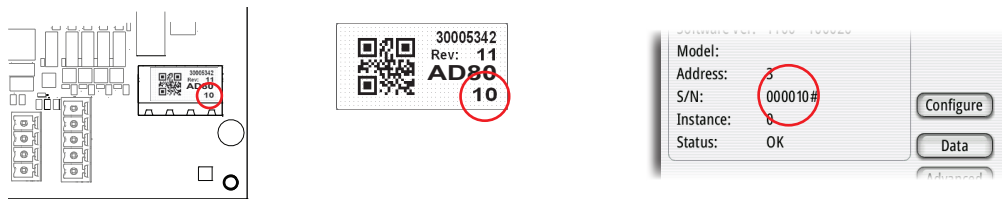

3. Select the Configure option to proceed to device configuration dialog. The dialog differs slightly for the different drive types

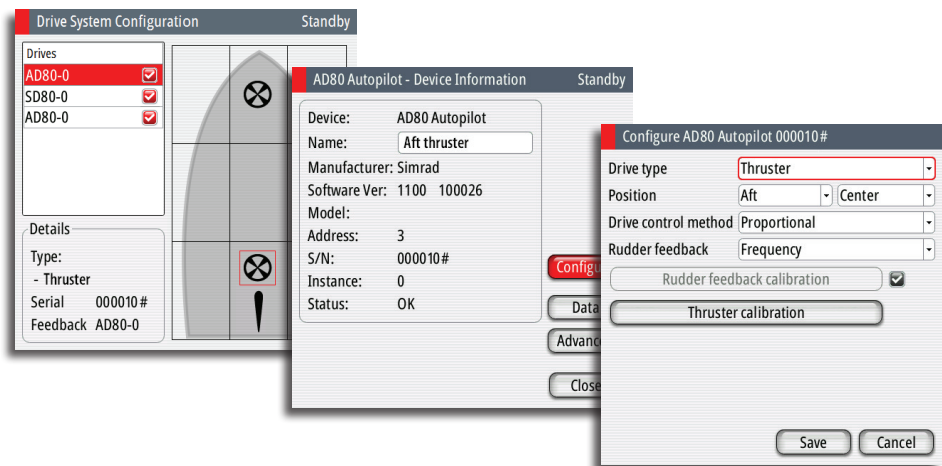

4. Select relevant settings for the selected drive, and save your settings

→ **Note:** There is no configuration when using an SG05 PRO. No Rudder- or Feedback calibration is required.

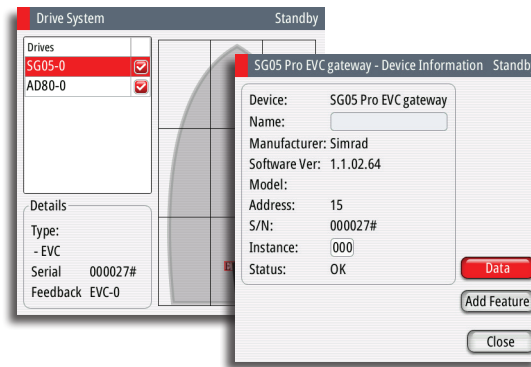

Advanced rudder settings

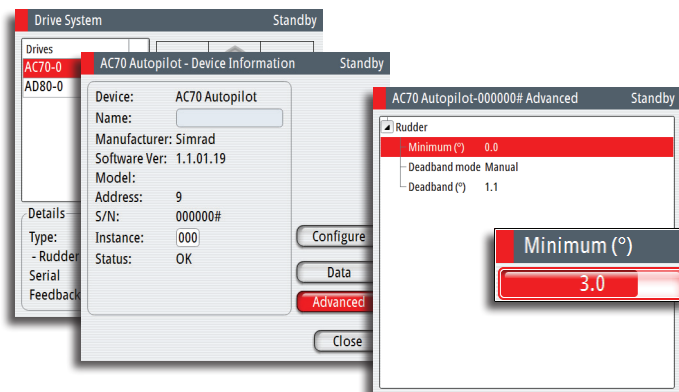

Minimum rudder

Some boats may have a tendency of not responding to small rudder commands around the course keeping position because of a small rudder, a rudder deadband, whirls/disturbance of the water-stream passing the rudder or it is a single nozzle water jet boat.

By manually adjusting the minimum rudder function, the course keeping performance might be improved on some boats. This will however increase the rudder activity.

→ **Note:** Only set a value for minimum rudder if it proves to give a better course keeping performance in calm sea. It should be set after the autotune has been performed and a fine tuning of the rudder parameter.

Rudder deadband

Prevents the rudder from hunting caused by high rudder speed and/or overshoot in the steering gear.

Deadband mode

Auto or Manual (default: Auto).

- **Auto:** The rudder deadband is adaptive and is continuously operative. It will also optimize the deadband to the speed of the vessel and the pressure on the rudder.
- **Manual:** If the Auto setting doesn't perform properly due to extreme rudder speed and/or overshoot, it can be adjusted manually.

Find the lowest possible value that will prevent the rudder from continuous hunting. A wide deadband will cause inaccurate steering. It is recommended to check rudder stability in AUTO mode at cruising speed to get pressure on the rudder. (Slight hunting observed dockside may disappear at cruising speed.)

Range: 0,1 – 4 (default: 0,5)

Configuring the handshake

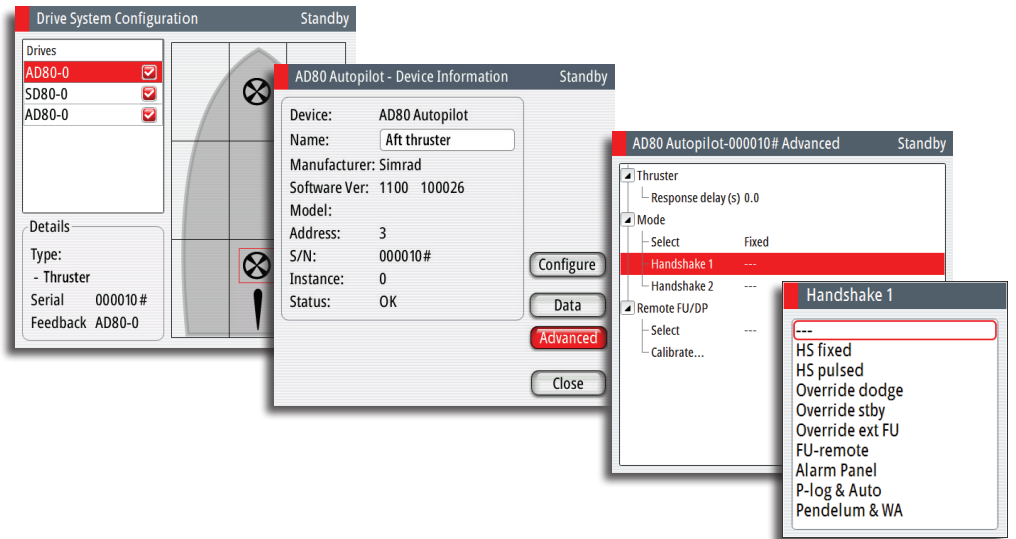

Handshake settings

Handshake setting	Function	Description
HS fixed	Autopilot/steering gear interface with fixed level signals	Output contact is closed when autopilot requests steering gear control. Input to be closed as long as steering gear is available for autopilot control (normally a “ready” signal).
HS pulse	Autopilot/steering gear interface with pulse signals	Output contact is closed for 1 sec when autopilot requests steering gear control. Input to be closed as long as steering gear is available for autopilot control.
Override Dodge	Manual override with fallback to AUTO	When input contact is closed, autopilot will give override warning, acknowledge with closed output contact and go to STBY mode. When input opens, output contact will open and autopilot returns to AUTO mode on present heading. Typically used for joystick hand steering with override button on top. → Note: must be limited to one autopilot computer board
Override STBY	Manual override to STBY	When input contact is closed, autopilot will give override warning, acknowledge with closed output contact and lock to STBY mode. When input opens, output contact will open and autopilot will unlock. This function is normally related to regulations for automatic override when main hand steering is operated. → Note: Must be limited to one autopilot computer board
Override ext FU	Unconditional external FU/DP control	When input contact is closed, autopilot will respond with closed output, display “External” and use the installed current or voltage input to the RUD UI plug of SD80/AD80 board for follow up rudder control. → Note: Must be limited to one autopilot computer board

Handshake setting	Function	Description
FU-remote	External FU/DP control by command transfer	When input contact is closed, a command transfer dialogue is started (refer Command transfer description in the AP70/AP80 Operator Manual). When accepted, the output contact will close and use the installed current or voltage input to the RUD UI plug of SD80/AD80 board for follow up rudder control. Output will open if control is taken from another unit again.
Alarm panel	Interface to central alarm panel with direct I/O	Refer "Central alarm panel with direct I/O interface" on page 36.
P-log & Auto	Pulse log input, auto mode output	If a pulse log of 200 p/NM to the input, it will show up as a speed source on the CAN network. The output will be a closed contact whenever the autopilot is in AUTO, NoDrift or NAV/TRACK mode. The signal can be used for reducing oil flow to rudder, watch alarm activate etc.
Pendulum & WA		If input signal is closed, steering and monitor compass will be offset by 180°. Output contact will close for 0.5 sec when active control unit is operated. Can be used for watch alarm systems that require information about operation of equipment.

Pendulum feature

The pendulum feature is intended for pendulum ferries where it is required to turn the heading 180° when the vessel is going «backwards».

The feature can be included in AP70/80 systems equipped with SD80 or AD80 boards. It can only be used for NMEA 0183 heading sensors, RC42 and CDI80.

The function is activated by using an external switch. When the contact is closed the system will add 180° to the heading received on the NMEA 0183 interface on SI80 and AC70. The heading is changed before heading data enters the CAN bus network, and all instruments on the bus will pick up the modified heading.

Configuration

The AP70/AP80 must be configured for the pendulum function as shown below.

Select Pendulum & WA for handshake 1 or 2, depending on physical connection of external switch.

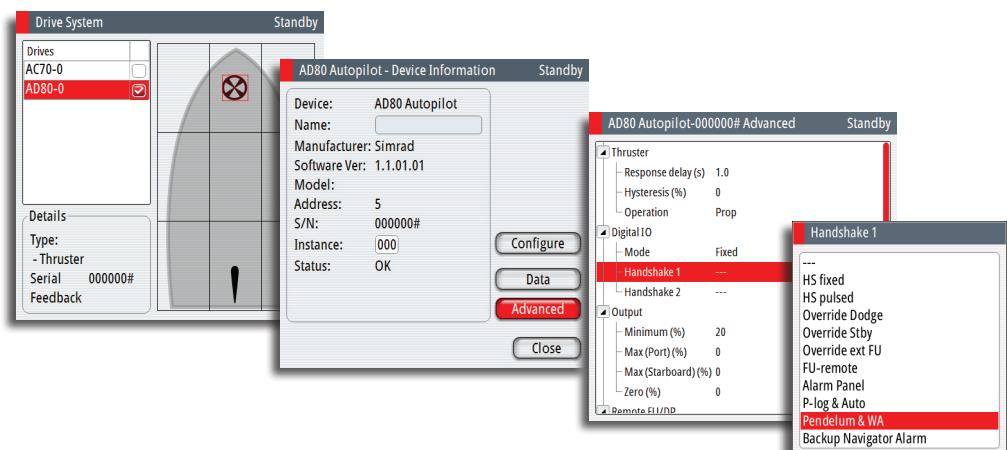

Setting up the AP80 for track steering

Configuring the ECDIS

The ECDIS system must be set up with source type set to Autopilot, and the system must be set up to listen for TNT messages.

Configure the ECDIS system to use the same primary sources as used by the AP80 system (Log, HDG, SOG, COG and POS).

Refer to the software/system configuration in the ECDIS manuals.

Configuring the AP80

The SI80 board uses the serial RS422 (IEC 61162 -1/2) standard. Ensure that the line is configured to use the same baud rate as the ECDIS system.

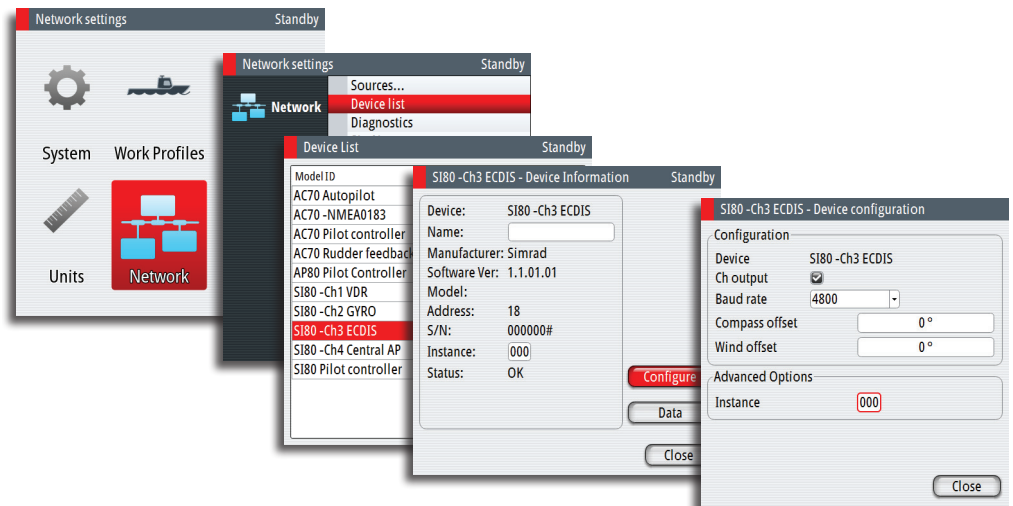

Rudder feedback/tunnel thruster feedback calibration

If a rudder or thruster feedback is available, this must be calibrated. This is required for the autopilot to know signal for mid-position, port/starboard side and rudder movement range.

→ **Note:** The graphics below shows the dialog when the rudder is controlled by an SD80. The configuration dialog varies with drive device and drive type.

1. Select feedback calibration option in the device configuration dialog

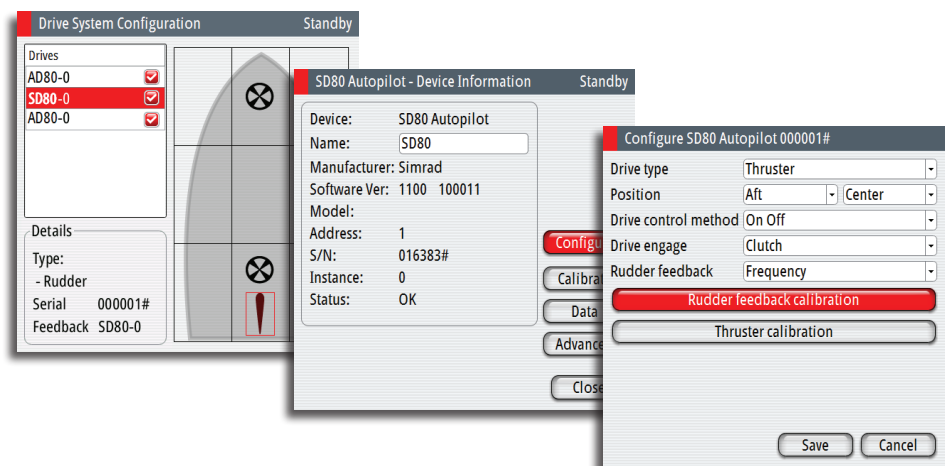

2. Follow the guided steps through the calibration process
3. Save the settings when completed

Drive test/calibration

When the drives are configured and calibrated, the autopilot need to know drive output level for standstill, polarity for port/stbd movement, the speed/signal- level relationship and max signal levels allowed. This is learned during the drive test or drive calibration.

1. Select test option in the device configuration dialog

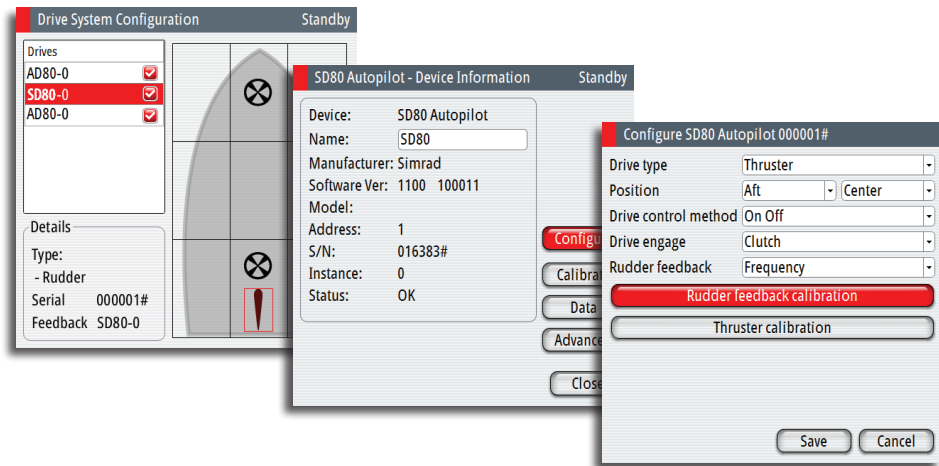

2. Follow the guided steps through the testing process
 3. Save the settings when completed
- **Note:** When a rudder feedback signal is set in the configure view, the feedback must always be calibrated before drive test or drive calibration is allowed.

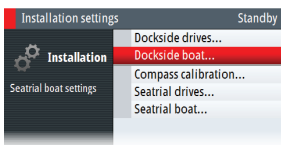

Vessel configuration

- **Note:** The unit of measurement in the dialog reflects your unit settings.

Boat type

The boat type setting is used by the system to select appropriate preset steering parameters. It will also affect available autopilot features.

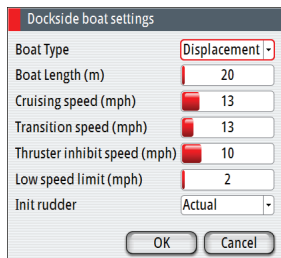

Boat length

The boat length affects the steering parameters.

- Range: 5 - 500 (m)

Cruising speed

The cruising speed is used if no speed info is available, and if manual speed is set to Auto. It is also used by the autopilot system to calculate steering parameters.

- Range: 2 - 50 (kn)
- Default: 15 (kn)

Transition speed

- **Note:** Only available if the boat type is set to planing.

The transition speed is the speed at which the system automatically changes from LOW to HIGH work profile.

These two work profiles are automatically defined when you set the boat profile to planing. The work profiles are set up with high and low speed parameters to control the different steering characteristics before and after planing.

On power boats it is recommended that you set a value that represents the speed where the hull begins to plane or the speed where you change from slow to cruising speed.

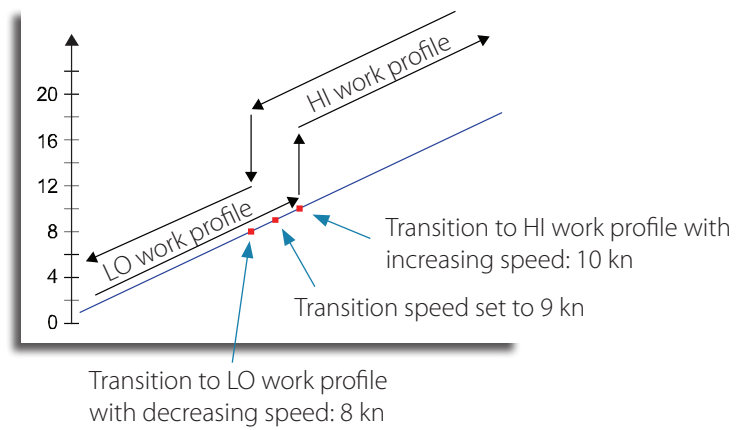

- Range: OFF - 40 (kn)
- Default: OFF

Thruster inhibit speed

This feature will block the thruster from running above a set vessel speed. It is a safety feature to prevent, especially electrical on/off thrusters, from overheating if out of water or for instance a planing boat or in rough weather.

When the speed exceed the set limit the thruster indication will change as shown below.

<i>Thruster(s) in use</i>	<i>Thrusters unavailable when speed exceed inhibit limit</i>

→ **Note:** The Thruster inhibit limit will only apply when speed source is Log or SOG, not if the speed is set manually.

- Range: 1 - 40 (kn)
- Default: 6 (kn)

Low speed limit

Sets the limit for the low vessel speed alarm.

An alarm occurs when the vessel's speed goes below the selected limit.

- Range: 1 - 20 (kn)
- Default: 1 (kn)

Init rudder

Defines how the system moves the rudder when switching from power steering to an automatic mode:

- Midships moves the rudder to zero position.
- Actual maintains the rudder offset, and use this as trim value (bumpless transfer)

→ **Note:** Actual is only available with rudder feedback signal available.

- Default: Midships

Seatrials

Compass calibration

All magnetic compasses must be calibrated as part of the autopilot seatrial procedure.

Before the compass calibration is started, make sure that there is enough open water around the vessel to make a full turn.

The calibration should be done in calm sea conditions and with minimal wind to obtain good results. Follow the on-screen instruction, and use about 60-90 seconds to make a full circle.

1. Start the calibration by selecting the Calibrate button in the device calibration dialog
2. Follow the online instructions

During the calibration, the compass will measure the magnitude and direction of the local magnetic field.

- If the local magnetic field is stronger than the earth's magnetic field (the local field is reading more than 100%), the compass calibration will fail
- If the local field is reading more than 30%, you should look for any interfering magnetic objects and remove them, or you should move the compass to a different location. The (local) field angle will guide you to the local interfering magnetic object.

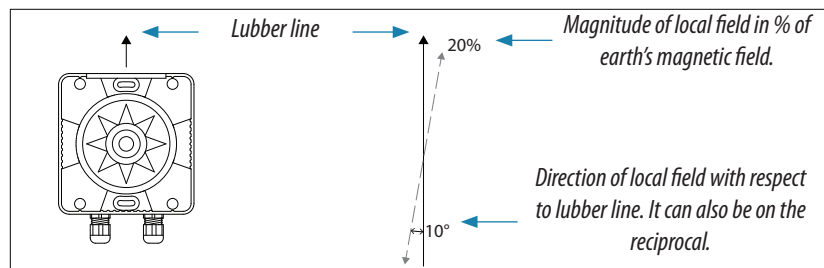
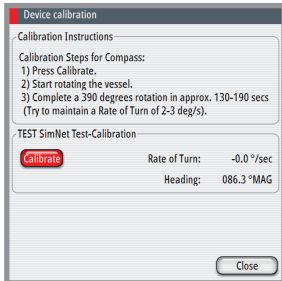

- ➔ **Note:** Calibration must be made on the compass that is active for the autopilot. If another model compass from Simrad or another manufacturer is installed, refer to the calibration instruction for that compass.
- ➔ **Note:** In certain areas and at high latitudes the local magnetic interference becomes more significant and heading errors exceeding $\pm 3^\circ$ may have to be accepted.

Compass mounting offset

The difference between the compass lubber line and the boat's center line should be compensated for.

1. Find the bearing from the boat position to a visible object. Use a chart or a chart plotter
2. Steer the boat so that the center line of the boat is aligned with the bearing line pointing towards the object
3. Activate the device configuration dialog as shown below
 - Ensure that the active compass is selected
4. Change the offset parameter so that the bearing to the object and the compass readout becomes equal

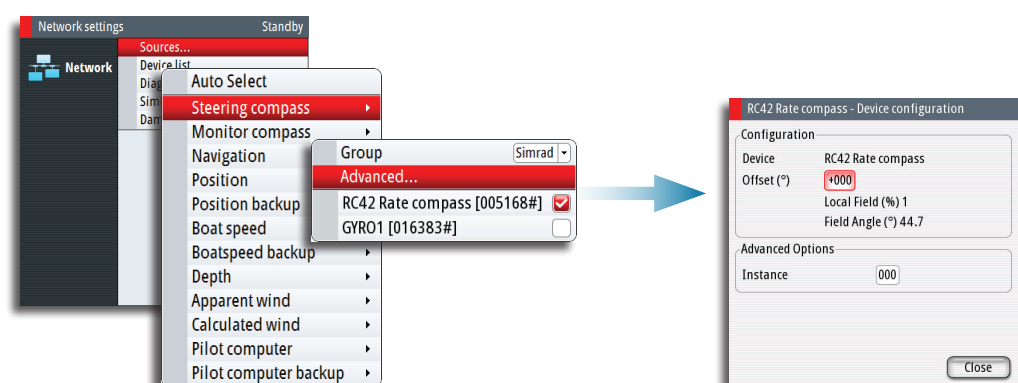

→ **Note:** Make sure that both the compass heading and the bearing to the object have the same unit (Magnetic or True).

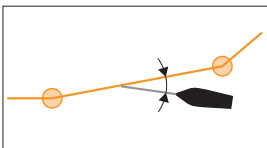
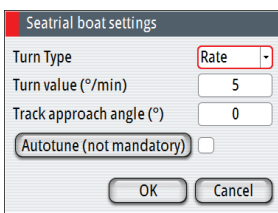
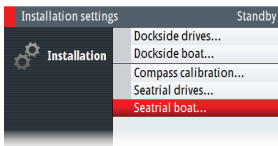
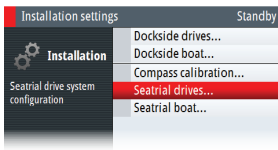

Drive configuration

The drive setup can usually be done while at dock, and only minor adjustments may be required at seatrial.

Refer "Dockside - Drive system" on page 46.

Boat settings

These settings are used as initial values for the vessel. Each of them can be changed in the different work profile settings.

Turn type and Turn value

Used for selecting how you want to control the vessel's turn: either by defining the Rate of Turn (Rate) or the radius.

- Rate range: 5°/minute - 720°/minute
- Radius range: 10 (m) - 10 (NM)
 - The minimum radius can however never be less than the value corresponding to a Rate of Turn = 720°/minute at the set Cruising speed
- Default: Rate
- Initial value: Determined during sea trial

Track approach angle

Defines the angle used when the vessel is approaching a leg.

This setting is used both when you start navigating and when you use track offset.

- Range: 5° - 60°
- Default: 30°

Tuning the autopilot for optimum steering performance

Providing you have entered correct vessel type, length and cruising speed, you may not have to perform further manual- or automatic tuning. Refer "Vessel configuration" on page 52.

→ **Notes:**

- If steering compass is magnetic type, perform any autopilot tuning steering East or West, as this will yield the best-balanced parameters
- The speed during tuning should be as close as possible to cruising speed. Ensure that this is set correctly and as described in "Vessel configuration" on page 52
- Active work profile that should be used during seatrial depends on vessel type.
 - For displacement boats **NORMAL** work profile should be used
 - Planing boats will have to tune both **LO SPD** and **HI SPD** work profiles
- All tuning should always be performed in open waters at a safe distance from other traffic

Initial automatic learning process

Before doing any manual or automatic tuning the autopilot needs to learn the turn characteristic of the boat. This is done in **AUTO** mode by making a major course change (min 90°) to port and starboard. For this test you may use the U-turn function (180°).

The autopilot will now find the appropriate amount of rudder to maintain the set turn rate during the turn. See also "Turn type and Turn value" on page 55.

When the automatic learning process is done, now proceed as follows to verify satisfactorily steering:

1. Stabilize the vessel on a heading, and then select **AUTO** mode
2. Observe course keeping and rudder commands
 - The autopilot should keep the vessel on the set heading within an average of +/-1 degree, providing calm sea and wind

3. Make some small and bigger heading changes to port and starboard and observe how the vessel settles on the new heading
 - The vessel should have a minimum of overshoot (see example "Manual tuning" on page 56)

If the autopilot is not keeping the heading satisfactorily or not making the turns satisfactorily, you may now either try the Autotune function or go directly to Manual tuning.

- **Note:** If the vessel is more than approximately 30 m/100 ft it may be unpractical to perform Autotune, and it is suggested to proceed with manual tuning.

Both Autotune and Manual tuning should be performed in calm or moderate sea conditions.

Autotuning

When performing an Autotune, the vessel will automatically be taken through a number of S-turns. Based on the vessel behavior, the autopilot will automatically set the most important steering parameters (Rudder and Counter rudder). The scaling factors for the parameters are set automatically as a function of the set boat type.

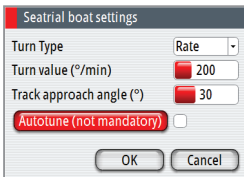

1. Stabilize the vessel on a heading
2. Set the speed is as close to cruising speed as possible
3. Start autotuning from the dialog
 - The pilot will take control of the vessel. Autotuning may take up to 3 minutes to complete

After the autotuning is completed the autopilot will return to **STBY** mode, and the rudder must be controlled manually.

- **Note:** Autotuning can be stopped at any time by selecting **Cancel**.

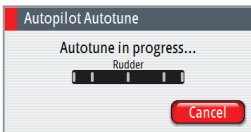

Manual tuning

1. Stabilize the vessel on a heading, and then select **AUTO** mode
2. Set the speed as close to cruising speed as possible
3. Activate the Quick menu by pressing the **MENU** key
4. Select **Rudder** and adjust according to the description below
5. If required, adjust slightly **Counter** rudder

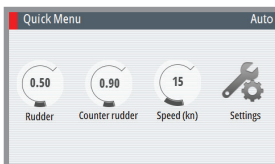

Rudder

This parameter determines the ratio between commanded rudder and the heading error. The higher rudder value the more rudder is applied.

- A. The the value is set too high. Steering becomes unstable and often the overshoot will increase
- B. Rudder is too small. It will take a long time to compensate for a heading error, and the autopilot will fail to keep a steady course



- Range: 0.05 - 4.00
- Default: Defined by system based on boat type and length

Counter rudder

Counter rudder is the amount of counteracting (opposite) rudder applied to stop the turn at the end of a major course change.

The settings depends on vessel's characteristics, loaded/ballast conditions and rate of turn.

- If the vessel has good dynamic stability, relatively small settings will be sufficient
- An unstable vessel will require high settings

- The greater the vessel's inertia, the greater value will be required
Increasing counter rudder settings may result in some higher rudder activity also when steering a straight course.

The best way of checking the value of the Counter rudder setting is when making turns. The figures illustrate the effects of various Counter Rudder settings;

- A.** Counter rudder too low; overshoot response
- B.** Counter rudder too high; sluggish and creeping response
- C.** Correct setting or counter rudder; ideal response

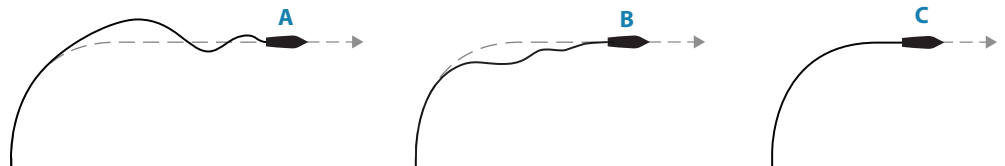

Perform various course changes and observe how the boat settles on the new heading. Start with small changes, 10-20 degrees and proceed with bigger changes, 60-90 degrees. Adjust Counter rudder value to obtain best possible response as illustration C below.

→ **Note:** As many boats turn differently to port versus starboard (due to propeller rotation direction), do the course changes in both directions. You may end up with a compromise setting of Counter rudder that gives a little overshoot to one side and a bit sluggish response to the other.

- Range: 0.05 - 32.00
- Default: Defined by system based on boat type and length

5

The alarm system

The AP70/AP80 system will continuously check for dangerous situations and system faults while the system is running.

Message types

There are two type of messages:

- Alarms
 - Generated when conditions are detected that critically effect the capability or performance of the system.
You must critically examine all alarm messages to determine their course and effect.
- Warnings
 - Informing you of conditions that could result in unwanted system response or eventual failure

Alarm indication

When an alarm situation occurs, siren will sound, the alarm icon will be active. The alarm dialog will show alarm cause, followed by the name of the device that generated the alarm.



Message type	Status	Icon		Alarm dialog	Siren
		Color	Appearance		
Alarm	New	Red	Flashing	Yes	Until acknowledged
	Acknowledged		Steady	Closed	Muted
Warning	New	Yellow	Steady	Yes	2 seconds
	Acknowledges			Closed	No

The alarm and alarm details are recorded in the alarm listing. Refer "The alarm dialogs" on page 59.

The icon

The alarm icon will remain on the display until the reason for the alarm/warning is removed.

The Alarm dialog

All new alarms and warnings activates the alarm dialog. The dialog will be closed when the message is acknowledged.

If more than one message is activate, this will be indicated in the alarm dialog. Only the cause for the most recent message will be displayed. The remaining messages are available in the Alarms listing as described on page 59.

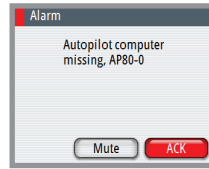

Single active alarm

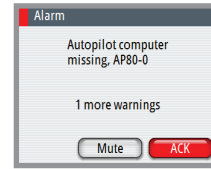

Multiple active alarms

Acknowledging a message

There is no time-out on the alarm message or siren. These remain active until you acknowledge it or until the reason for the alarm is removed.

The following options are available in the alarm dialog for acknowledging a message:

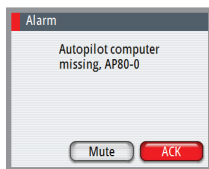

Option	Result
ACK	Sets the alarm state to acknowledged, meaning that you are aware of the alarm condition. The siren will stop and the alarm dialog will be removed. The alarm icon will however remain active, and the alarm will be included in the alarm listing until the reason for the alarm has been removed
Mute	Mutes the siren locally. The alarm dialog remains on the display

The alarm dialogs

The system includes three different alarm displays:

- Active alarms
 - List of all active messages
- Alarm history
 - Alarm events, including alarm type and time/date
- Alarm settings
 - List of all alarms that can be enabled and configured by the user

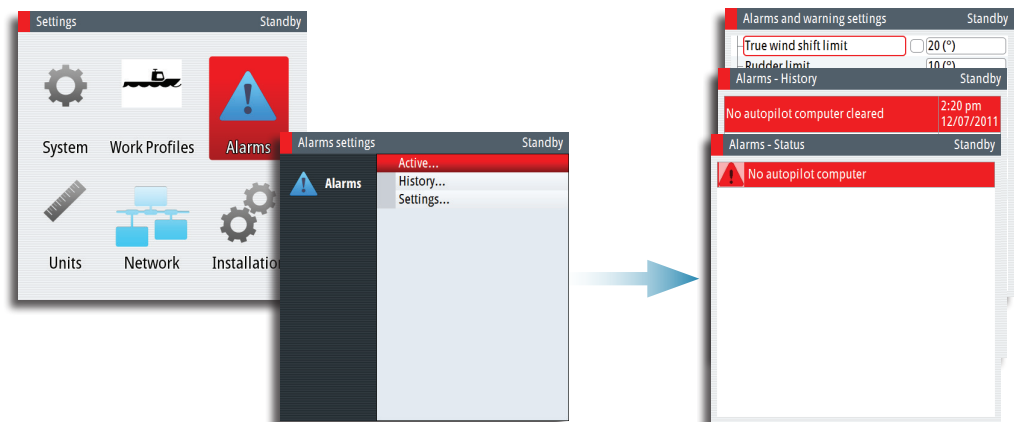

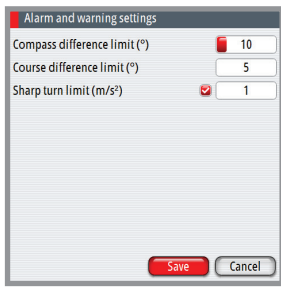

Setting the alarm and warning limits

The alarms and warning limits are adjusted from the settings display.

1. Activate the alarm settings dialog as shown above
2. Select the parameter to be changed
3. Press the rotary knob to edit the value
4. Change the value by using the rotary knob or the arrow keys
5. Repress the rotary knob to confirm your setting

Only a few alarms can be turned off. These are indicated with a check box, and are turned on/off by pressing the rotary knob.

- **Note:** Additional alarm limits that can be defined for each Work profile. Refer to Work Profile description in the Operator Manual.

Compass difference limit

When two compasses are used (main compass and monitor compass), there is virtually always a difference between the readings of the two. If the difference exceeds the set limit, an alarm is given.

- **Note:** The difference between the two compass readings may vary with the vessel's heading and from one area to another where a vessel is in transit. The difference between the two compass readings is automatically reset when a Compass diff. alarm is acknowledged.
- Range: 5° - 35°
 - Default: 10°

Course difference limit

Sets the value the actual heading can differ from track course.

- Range: 5° - 35°
- Default: 35°

Sharp turn limit

Gives a warning if a turn is started in any auto mode with a combination of speed and turn rate/radius that will cause sidewise acceleration bigger than set limit.

- Range: OFF / 1 - 10 m/s
- Default: OFF

Fallback and failures during automatic steering

Rudder angle sensor missing

Alarm will be given and steering will after 0.1 sec continue using "virtual" rudder angle data (virtual is estimated value based on known rudder speed)

Steering compass missing

When monitor compass is available

Alarm for main compass failure is given and steering continues using monitor compass. If there is a difference between the compasses, a smooth transition (2 min filter) to the monitor compass heading takes place.

When acknowledging the alarm, the autopilot goes to **STBY** mode.

When no monitor compass

Rudder is kept at fixed angle (i.e. heading is approximately maintained if failing when heading keeping, turn is approximately maintained if failing when turning), alarm is given and autopilot goes to **STBY** mode.

Magnetic variation missing

If heading source is set to be adjusted for magnetic variation, variation is taken from available sensors in following order: Position source – Navigation source – Compass – any other variation available on CAN bus. If variation disappears, last valid variation will be used until automatic steering is cancelled and heading shown will then be corrected according to alternative variation in the order given above.

Jump in heading data

If there is an abnormal heading jump in steering compass heading, an alarm (check heading) will be given and a smooth transition to new heading will take place. There may also be a compass difference alarm if a monitor compass is in use.

Speed sensor lost

If speed in use is lost there will be an alarm and smooth transition (2 min filter) to fallback speed. Speed for steering and speed for navigation will use following use priority and fallback:

Steering:	STW	STW backup	SOG	SOG backup	Manual speed	Cursing speed
Navigation:	SOG	SOG backup	STW	STW backup	Manual speed	Cruising speed

Position data missing

During NoDrift steering, alarm is given and a smooth transition to position backup source takes place. If no position backup steering source, steering mode will change to auto heading.

Navigation data missing

If lost during track/nav. steering, give alarm and change to auto heading steering.

Local supply voltage missing

When control unit(s) and CAN bus have different power source, alarm will be given on active control unit with sound and flashing red power button led (display will go "black"). Main steering computer will go to **STBY** mode and activate alarm on all other control units.

CAN bus supply voltage missing

Active control unit will give local alarm and rudder/thruster drive units will go to **STBY** mode.

Rudder/thruster drive computer failure

Alarm will be given and the ready signal to the steering /thruster gear will disappears. If sw failure, there will be a watchdog restart of failing drive computer. The autopilot steering computer will try to maintain steering as far as possible with remaining drive computers. If the faulty unit is the autopilot steering computer, autopilot backup computer has to be selected manually (ref. Menu- source selection).

List of possible alarms and corrective actions

The next pages includes a list of all alarms generated by the autopilot system.

The AP70/AP80 control units might also display alarms received from other units connected to the system. Refer separate documentation for the relevant equipment for further descriptions of these alarms.

Alarm/Warning	Type	Warning/Alarm condition	Possible cause and recommended action
Red flashing AP70/AP80 power button, black display	A	< 5 V	Local supply voltage to AP70/AP80 missing or <5 V. Check local supply, connections and fuses to AP70/AP80 control units
Active control unit missing	A	Autopilot computer has lost contact with active control unit	Active control unit goes silent. 1. Check/repair CAN bus cable 2. Replace the control unit
Autopilot computer missing	A	Active control unit has lost contact with autopilot computer	Faulty autopilot computer or poor cable connections from the same. 1. Check connectors and cable 2. Check local power to control unit 3. Check that control unit is turned on 4. Replace autopilot computer → Note: Since this alarm may be given by several units at the same time, it has no device tag.
Boat speed missing	W/A	Lost sensor data	The speed signal from the GPS or the log is missing. 1. Check Device list for valid speed source 2. Try a new automatic source update 3. Check the GPS, log, and cable connections
CAN bus failure	A	Not possible to send or receive data although bus voltage is ok	Poor CAN bus backbone, defective cable/connector or defective CAN bus receiver in autopilot control unit. 1. Check backbone terminations 2. Check cable and connectors 3. Replace Autopilot control unit
CAN bus supply overload	W	Current >4.3 A	Check summary unit loads
	A	Current >10 A for 1 ms, hw shutdown	Excessive current draw. Check for short circuit/defective device on network.
Check heading	A	Lasting steering compass heading jump >10° within 1 sec during automatic steering	A sudden jump in heading of more than 10 degrees is detected Check steering compass. Possibly change to other heading source or monitor compass.
Compass difference	A	Difference between steering compass and monitor compass +variance > set limit	The difference in readings between the main compass and the monitor compass exceeds the limit set for "Compass difference". Check the operation of both compasses. If one compass is magnetic, the error may be caused by deviation change or heavy sea disturbances.
Course difference	A	Actual heading diff from track course by set limit	Compass heading is deviating too much from the track course (BWW). May be caused by extreme wind and current, combined with low speed.
Cross track distance limit	W/A	XTD > XTD limit	XTD has reached set XTD limit in NAV/TRACK mode. May be caused by extreme wind and current or too low boat speed.
Drive inhibit	A	Motor or solenoid drive electronics critically overloaded	Check for wire shortage, eventually disconnect suspicious wires.
No drives available	A	None of the drives selected in present work profile is available for steering	Check that use of thruster(s) has been activated by CMD/THRUSTER button. Check that steering gear/thruster is started and set for autopilot control. Check if speed is below thruster inhibit limit. Check if drive is unavailable for other reason (ref. Drive ready missing alarm).

Alarm/Warning	Type	Warning/Alarm condition	Possible cause and recommended action
Drive ready is missing	A	No drive available response upon request from autopilot on Handshake port of faulty SD80/AD80 board	Check that steering gear/thruster is started and set for autopilot control. Check cabling to Handshake port of faulty SD80/AD80 board. Make sure Handshake port of faulty SD80/AD80 board is configuration for HS fixed/HS pulse (refer "Note: There is no configuration when using an SG05 PRO. No Rudder- or Feedback calibration is required." on page 48.
Drive reference voltage missing	A	Reference voltage to faulty AD80 is missing	Check that the two U_CTRL dip switches of faulty AD80 board is set correctly (ref. cable connection label inside faulty unit). If drive control signal is 4-20 mA current or voltage using internal ± 10 V reference, switches must be set to INT . If external ref. voltage is connected switches must be set to EXT . If ext. ref. voltage, check cabling and measure correct voltage between U_REF+ and U_REF- of AD80 board
Drive computer is missing	W/A	Autopilot computer has lost communication with faulty device	Check that green CPU led of faulty unit is alternating (ref. label inside unit cover for location of led). If off, check local power supply/fuse (AC70). For other boards, check CAN supply for 9-15 V between NET-S and NET-C of SimNet plug. If led is ok, check cabling, T-connector backbone etc. If led is on, try to restart unit by turning power off/on
End of route	A	Given if WP name = "End of route"	Warning given on the active control unit when a "END ROUTE" waypoint name has been received from the Plotter/ECS.
ENGAGE output overload	W	Current > 3.5 A	Bypass valve or clutch is drawing excessive current (>3,5 A). Make sure there is no shortage to ground or cabling damage, disconnect cable from AC70 to motor, and make sure there is no alarm when engaging FU or Auto mode.
	A	Current > 5 A	
EVC comm. error	A	Lost communication with EVC system (Volvo IPS and similar).	Check connection with EVC engine interface. For IPS, engine must be running.
External mode illegal	A	Signals to external mode input port of faulty SD80/AD80 board has illegal combination	Check if alarm is given for a certain position of external mode selector. Check cabling to MODE SEL port of faulty board
High internal temp.	W	>75°C	Excessive temperature in unit (>75°C).
High drive temp.	W	Drive electronic temperature >80°C	Excessive temperature in Autopilot Computer drive transistors (>80°C), possible long term overload. <ol style="list-style-type: none">1. Switch off autopilot2. Check for backload in Drive unit/steering system.3. Check that the autopilot computer specifications matches Drive unit
	A	Drive electronic temperature close to critical for more than 1 s.	
Low CAN bus voltage	W	< 9 V	Check cable length, bus load and bus supply feeding point. If possible, check if fault disappears by disconnecting some units
Low supply voltage	W	<10 V (12 V -15%)	Mains voltage less than 10 Volts. <ol style="list-style-type: none">1. Check battery/charger condition2. Verify mains cable has correct gauge
Low boat speed	W/A	Speed below set limit for steering in Work profile	Speed below set limit for acceptable course keeping (in Work profile). Switch to hand steering or adjust Work profile settings.
Monitor compass missing	W	Lost sensor data	No data from the selected monitor compass. (Warning only.)

Alarm/Warning	Type	Warning/Alarm condition	Possible cause and recommended action
Navigation data missing	W/A	Lost sensor data (NAV mode)	Navigation data from Plotter/ECS is missing. <ol style="list-style-type: none"> 1. Check Device list for valid navigation source 2. Try a new automatic source update 3. Check the Plotter/ECS and cable connections
New WP	A	Ref. "Course change confirm limit" in NAV	Nav mode only; Course change from one leg to the next is exceeding set "Course change limit"
No rudder response	A	No response to rudder command	<ol style="list-style-type: none"> 1. Check all connections 2. Check Rudder FB transmission link (not applicable for Virtual feedback installations) 3. Check drive unit motor/brushes 4. For SD80, check that port/stbd led is activated (ref label in cover for location) 5. Replace the Autopilot Computer Drive board
Off heading	A	Boats heading is outside set off heading limit. Automatic reset when inside limit	May be caused by extreme weather conditions, and/or too slow speed. <ol style="list-style-type: none"> 1. Check steering parameters (Rudder, Autotrim, Seastate-filter) 2. Increase Response/Rudder value 3. Increase boat speed, if possible, or steer by hand
Override	W	<ol style="list-style-type: none"> 1. EVC override via SG05 2. Override via SD80/AD80 Handshake (ref. KaMeWa) 3. Override via SD80/AD80 RUD UI port 	If unintended warning, make sure override handle is not being activated by loose objects. Check cabling and override switches connected to Handshake port of faulty SD80 or AD80 board
Position data missing	W/A	Lost sensor data (NoDrift mode)	Position data from the GPS is missing. <ol style="list-style-type: none"> 1. Check Device list for valid position source 2. Try a new automatic source update 3. Check the GPS and cable connections
Rudder data missing	A	Rudder angle signal to faulty board is missing	If several rudder angle sensors, check which one the faulty board is set up for use (refer "Drive test/calibration" on page 52). If the missing sensor is connected to an autopilot computer check cabling to the board. If missing sensor is a CAN device, check backbone bus network connection.
Rudder limit	W	Limit rel. to rudder cmd in auto modes. Not applicable for NFU/FU where rudder shall stop at max -3°	The set rudder limit has been reached or exceeded. This is a warning only and may be caused by disturbance to compass (waves), speed log, sharp turn or improper parameter setting.
No rudder response	W	Rudder error >1° when rudder command > 0.5%/s	Excessive load on steering gear. Air in hydraulic system. Insufficient drive unit capacity. <ol style="list-style-type: none"> 1. Look for mechanical obstructions at the rudder/tiller/quadrant. Check the back drive force 2. Bleed the hydraulic system 3. Replace with bigger pump unit
Sharp turn	W	Acceleration > set g-limit (Alarms - settings)	If unintended warning, check that the boat speed to the autopilot is correct. Check that set turn rate or radius corresponds to actual

Alarm/Warning	Type	Warning/Alarm condition	Possible cause and recommended action
Drive overload	W	AC70: Motor/sol current > 30 A SD80: Sol current >8 A	<p>Reversible motor</p> <p>Motor stalls or is overloaded</p> <ol style="list-style-type: none"> 4. Fix possible mechanical blocking of rudder. 5. If heavy sea at high rudder angle, try to reduce boat speed or rudder angle by steering at another heading 6. Make sure there is no shortage to ground or cabling damage, disconnect cable from AC70 to motor, and make sure there is no alarm when trying to run NFU-mode <p>Solenoids</p> <p>Shortage to ground or cabling damage. Same action as for motor</p>
	A	AC70: Mot/sol current > 55 A SD80: Sol current > 9 A	
Steering compass missing	A	Lost sensor data	No data from the selected steering compass. If no monitor (back up) compass; the autopilot goes to STBY mode. If Monitor compass; the autopilot switches to monitor compass. If there is a difference the autopilot will gradually synchronize with the new heading (2 minutes).
Thruster inhibited	W	Vessel speed > set limit	<p>The vessel speed exceed the set limit for when thrusters can be used.</p> <p>→ Note: The Thruster inhibit limit will only apply when speed source is Log or SOG, not if the speed is set manually.</p>

6

Installation checklist

General

When all units are installed, external equipment connected and the software configured according to the previous sections, the installation should be verified according to the check lists in the following pages.

Checklist

Description	Refer	Yes/No	N/A
Units mounted and secured according to instructions	page 21		
CAN bus powered and terminated according to instructions	page 23		
Correct power and polarity to computer and control units	page 24		
Sources selected	page 42		
SimNet groups defined	page 44		
Master station defined	page 45		
Drive units configured and calibrated	page 46		
Vessel configured	page 52		
Compass calibrated	page 54		
Seatrial completed (Autotune)	page 56		
Seatrial completed (Manual tuning)	page 56		
Connected equipment approved according to notified body			
User training provided			

Date: _____

Signature Installer

Signature Captain

Installation settings

Drives

Setting	AC70	SD80	AD80
Configure			
Instance			
Name (product info method)			
Drive type			
Drive location alongside			
Drive location athwartships			
Drive control method			
Nominal drive voltage		N/A	N/A
Drive engage			N/A
Rudder feedback			
Rudder feedback calibration			
Advanced			
Min rudder			
Deadband mode			
Rudder deadband			
Thruster Response delay	N/A		
Thruster hysteresis	N/A	N/A	
Thruster operation	N/A	N/A	
Mode select	N/A		
Handshake 1	N/A		
Handshake 2	N/A		
Dither frequency	N/A		N/A
Dither amplitude	N/A		N/A
Max output port	N/A		
Max output stbd	N/A		
Rudder zero	N/A	N/A	
Zero output	N/A		
Min output			
Max output			N/A
Remote FU/DP	N/A		
Remote FU/DP calibrate	N/A		

Boat

Setting	
Dockside boat	
Boat type	
Boat length	
Cruising speed	
Transition speed	
Thruster inhibit speed	
Low speed limit	
Init rudder	

Setting	
Seatrial boat	
Turn type	
Turn value	
Track approach angle	

Work profiles

Setting						
Profile name	Normal					
Auto steering						
Turn						
Course response						
Economy						
Wave filter						
Adaption						
Rudder gain						
Counter rudder						
Autotrim						
Off heading limit						
Low speed limit						
Track steering						
Track response						
Track approach angle						
Course change limits						
XTD limit						
Drive select						
Rudder						
Init rudder						
Rudder limit						
Tow angle						
Thruster						
Thruster sensitivity						
Thruster assist						
Push boat to						
	Port					
	Starboard					

Installed unitsw

Unit	Type	Location	Date
Control units			
Remotes			
Computers			
Feedbacks			
Compass			
Other units			

7

Specifications

AP70 and AP80 Autopilot system

→ **Note:** For updated technical specifications, compliance and certifications, refer to our websites.

Boat type:	Power (displacement, outboard and planing). From 30 ft and up
Steering system types:	Hydraulic; Reversible pump/Solenoids Mechanical; Rotary drive/Linear drive. Max 6 rudder/thruster drives
Inter-unit connection:	CAN bus/NMEA 2000
System ON/OFF:	From control units
Supply voltage:	12/24 V DC +30 -10%
Power consumption:	Dependent on system configuration (See spec for individual units)
EMC protection:	IEC 60945: 2002-08
Performance:	IMO A.342(IX) & A.822(19), ISO 11674 & 16329
Rate of turn:	Within $\pm 10\%$ of preset value or $3^\circ/\text{min}$. Ref. ISO 11674: 4.3.7
Heading indication error:	$<0.5^\circ$. Ref. ISO 11674: 4.3.5
Heading stability:	Within $\pm 1^\circ$. Ref. ISO 11674: 4.3.13
Automatic Steering Control	
Rudder/thruster Drive	Reversible pump, solenoid on/off, proportional valve, analog
Sea state control	Adaptive sea state filter
Electronic interface:	
Serial data input/output ports::	AC70: 1 AC80, AC85, SI80: 4 Refer to "Supported data" on page 78
Heading sensors:	Gyrocompass, Fluxgate/Rate compass, Magnetic compass, GPS compass (NMEA)
Course selection:	Rotary course knob and buttons
Alarms:	Audible and visual, external optional (AC70)
Alarm modes:	See "The alarm system" on page 58
Steering modes:	STANDBY, Non-follow-up, Follow-up, AUTO, NoDrift, NAV
Special turn modes:	U-Turn

AP70 and AP80 Control units

	AP70	AP80
DISPLAY		
Size	5 in\127 mm	
Resolution (HxW)	480x480	
Type	16-bit color TFT	
Antifog	bonded	
Best viewing direction	any direction	
Backlight	Cold Cathode Fluorescent Lamp (CCFL)	
NETWORKING		
CAN bus	x	
USB	N/A	x
Ethernet	for sw update	
POWER		
Local supply	12/24 V DC +30-10%	
Consumption local supply	0.7/0.4 A at 12 V DC 0.4/0.3 A at 24 V DC backlight full/off"	
NMEA 2000 Load Equivalent number (50 mA)	1	
INTERFACE	External alarm/Active unit output max 100 mA, 4.5 A short circuit limit External Take CMD input, contact current max 8 mA	
ENVIRONMENT		
Temperature, operation	-30°C to +55°C (-22°F to 131°F)	
Temperature, storage	-25°C to +70°C (-13°F to 158°F)	
Protection	IPx4	IPx6
MECHANICAL		
Weight	1,2 kg (2.7 lbs)	1,4 kg (3.1 lbs)
Size	Refer "Drawings" on page 79	
Mounting	Panel (flush) or optional bracket	
Compass safe distance	0.4 m	
Material	Plastic	Epoxy coated seawater resistant aluminium, plastic front bezel
Color	Black and grey	
Cable inlet, refer "AP70 and AP80 Connector pinouts" on page 77	1 Power/alarm, 1 Micro-C con.	

Autopilot Computers

→ **Note:** For signal specification of the board(s), see “Computer boards” on page 74.

SI80, AC70, AD80 and SD80 computers



	SI80	AC70	AD80	SD80
Board				
SI80 board	x			
AC70 board		x		
AD80 board			x	
SD80 board				x
POWER				
Local supply	12/24 V DC, +30 - 10%. Need 12 V CAN supply		N/A	N/A
Consumption local supply	0,3 - 5 A CAN bus load dependent	100/65 mA at 12/24 V DC + load of connected equipment (motor, solenoids, clutch etc.)	N/A	N/A
NMEA 2000 Load Equivalent number (50 mA)	1	1	4	3
Output for CAN bus supply	15 V DC, +/- 5%, 4 A max	N/A	N/A	N/A
ENVIRONMENT				
Temperature, operation	-15°C to +55°C (5°F to 131°F)			
Temperature, storage	-30°C to +70°C (-22°F to 158°F)			
Protection	IPx2			
MECHANICAL				
Weight	0,9 kg (2 lbs)	1 kg (2.2 lbs)	0,5 kg (1.1 lbs)	
Size (length x width x height)	See “AC70 and SI80 Computer” on page 81		See “SD80 and AD80 Computers” on page 81	
Mounting	Bulkhead			
Compass safe distance	1 m			
Material	Plastic front and anodized aluminum back		Plastic	
Color	Black			
Cable inlet	Slots: 9 x 95 mm and 18 x 45 mm (0.4" x 3.7" and 0.7" x 1.8")			

AC80A, AC80S and AC85 computers

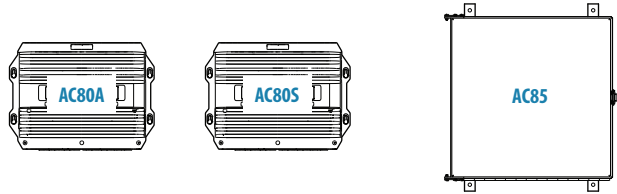

	AC80A	AC80S	AC85
Board			
SI80 board	x	x	x (1 Basic), (+1 optional)
AC70 board			Optional Max 4 boards
AD80 board	x		
SD80 board		x	
POWER			
Local supply	12/24 V DC +30-10%		
Consumption local supply			
NMEA 2000 Load Equivalent number (50 mA)	4	3	Config. dependant. Max 10
Output for CAN bus supply	15 V DC, +/- 5%, 4 A max		
ENVIRONMENT			
Temperature, operation	-15°C to +55°C (5°F to 131°F)		
Temperature, storage	-30°C to +70°C (-22°F to 158°F)		
Protection	IPx4		IPx4
MECHANICAL			
Weight	4,1 kg (9 lbs) (basic)		
Size (length x width x height)	See "AC80A and AC80S Computer" on page 82		See "AC85 Computer" on page 82
Mounting	Bulkhead		
Compass safe distance	1 m		
Color	Black		
Cable inlet	Grommets: 7 for cable diameter 7 - 10 mm (0.3" - 0.4") 4 for cable diameter 10 - 14 mm (0.4" - 0.6")		Grommets: 8 for cable diameter 10 - 14 mm (0.4" - 0.6") 7 for cable diameter 14 -20 mm (0.6" - 0.8")

Computer boards

	SI80	AC70	SD80	AD80
NETWORKING				
NMEA 0183, IEC 61162-1, IEC 61162-2, input	4 ch	1 ch		
NMEA 0183, IEC 61162-1, IEC 61162-2, output	4 ch	1 ch		
NMEA 0183, IEC 61162-1, IEC 61162-2, baud rate	4.8 & 38.4 kBaud	4.8 & 38.4 kBaud		
CAN bus	x	x	x	x
POWER				
Local supply	12/24 V DC +30 - 10%	12/24 V DC + 30 - 10%. Need 12 V CAN supply	N/A	N/A
Consumption local supply	0,3 - 5 A CAN bus load dependent	100/65 mA at 12/24 V DC + load of connected equipment (motor, solenoids, clutch etc.)	N/A	N/A
NMEA 2000 Load Equivalent number (50 mA)	1	1	2	2
Output for CAN bus supply	15 V DC, +/- 5%, 4 A max			
INTERFACE				
Reversible motor control of rudder/thruster	N/A	Max continuous load 30 A, peak 50 A for 1 sec	N/A	N/A
On/off solenoid control of rudder/thruster	N/A	12/24 V DC, common lo, load range 10 mA to 10 A. (Off state <1 mA)	Externally supplied 12/24 V DC, common hi or lo, load range 10 mA to 10 A. (Off state <1 mA)	N/A
Analog voltage control of rudder/thruster, internal supply	N/A	N/A	N/A	Range ±10 V, max load 5 mA
Analog voltage control of rudder/thruster, external supply	N/A	N/A	N/A	"Supply range: 5-24 V DC Control range: 5-95% of supply range with zero ref at min or half ref. voltage, max load 5 mA"

	SI80	AC70	SD80	AD80
Analog current control of rudder/thruster	N/A	N/A	N/A	4-20 mA
Proportional directional control of rudder/thruster	N/A	N/A	Solenoid control for direction, "Engage" output for speed	N/A
"Engage" output for bypass/clutch	N/A	12/24 V DC, min 10 mA, max 3 A	Externally supplied 12/24 V DC on/off or proportional, min load 10 mA, max load 3 A, superimposed dither 0-10% amplitude, off or 70-400 Hz	N/A
"Ready" output for rudder/thruster	N/A	N/A	Max load 100 mA, 32 V DC, sw and watchdog controlled, galvanic isolated (closed = ready), polarity independent	
Rudder angle, frequency input	N/A	15 V (out), 1.4 to 5 kHz, resol. 20 Hz/°, center 3.4 KHz	15 V (out), 1.4 to 5 kHz, resol. 20 Hz/°, center 3.4 kHz	
Rudder angle or remote FU/DP, voltage input	N/A	N/A	Ranges ±5 V, ±10 V, 0-5 V, 0-15 V	
Rudder angle or remote FU/DP, current input	N/A	N/A	4-20 mA	
NFU port/stbd input and mode indicator output	External open/close contact, common ret, contact current max 30 mA	External open/close contact, common ret, contact current max 30 mA	N/A	N/A
Mode input	N/A	External open/close or pulse contact for SYSTEM SELECT, common ret, close to activate, contact current max 30 mA	External open/close or pulse contact for SYSTEM SEL, STBY, AUTO, TRACK, common ret, close to activate, contact current max 30 mA	

	SI80	AC70	SD80	AD80
Programmable handshake output, 2 ports (Steering gear/thruster interface, Alarm panel, Watch alarm, Remote FU/DP acknowledge)	N/A	N/A	Internal open/close polarity independent solid state contact, galvanic isolated, max load 100 mA, 2 V DC	
Programmable handshake input, 2 ports (Steering gear/thruster interface, Alarm panel, Pulse log, Pendulum ferry, Mains steering wheel override, remote FU/DP request)	N/A	N/A	External open/close contact, contact current max 30 mA	
External alarm output for buzzer/relay	N/A	Max 100 mA, voltage level as local supply	N/A	N/A
EVC (Electronic Vessel Control) interface	N/A	CAN via SG05 Gateway	CAN via SG05 Gateway	

AP70 and AP80 Connector pinouts

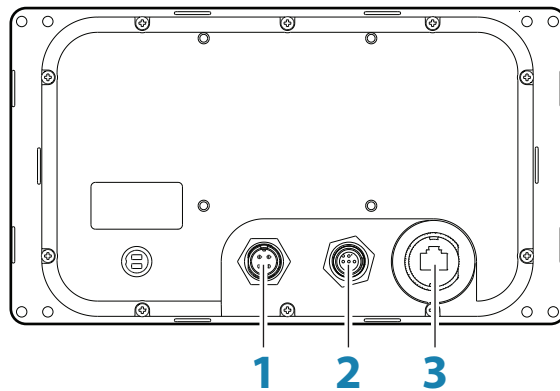

- 1 Power**
- 2 CAN bus**
- 3 Ethernet**

Power

Cable connector (female)

Layout	Pin	Wire Color	Function
	1	Black	Battery (-)
	2	Blue	Alarm/Active
	3	Yellow	External command
	4	Red	Battery (+), 12 - 24 V DC

Power cable

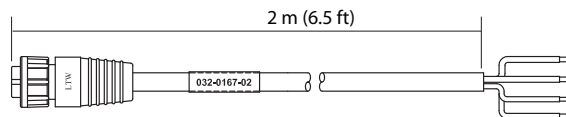

CAN/NMEA 2000

Micro-C cable connector (female)

Layout	Pin	Wire Color	Function
	1	(Bare)	Shield
	2	Red	NET S (+12 V)
	3	Black	NET C (-)
	4	White	NET H
	5	Blue	NET L

Ethernet

→ **Note:** Both straight and crossed Ethernet cable may be used for software upload (AP70)!

Supported data

IEC61162-1/2 interfaces channels

Channel	Default name (can be changed by user)
AC70	NMEA 0183
SI80-1	VDR
SI80-2	GYRO
SI80-3	ECDIS
SI80-4	BAM (Bridge Alert Management)

Sentences

Sentence	In	Out (numer is output repeat rate in Hz)					NMEA 2000 PGN	Comment
		AC70	SI80-1	SI80-2	SI80-3	SI80-4		
AAM	x						129284	
ACK	x		x*			x*	130850	* When alarm is acknowledged
ALR			x*			x*	130850	* When alarm activate, ack and deactivate
APB	x						129283,129284,129285	
BOD	x						129284	
BWC	x						129284	
DPT	x						128267	
GGA	x				1	1	129025,129029	
GLL	x				1	1	129025,129029	
HDG	x	10*	1*	10*			127250	* When magnetic heading source
HDT	x	10*	1*	10*			127250	* When true heading source
HSC	x						127237	
HTD			1		1	1	127237	
RMA	x						129025, 129026,127258	
RMB	x						129283, 129284	
RMC	x						127258,129025,129026,129033	
ROT	x			2			127251	
RSA		5	3	5	5	5	127245	
THS	x		3		10	10	127250	
TNT*	x				5		130862	* Proprietary track control
VBW	x						128259	
VHW	x						127250, 128259	
VLW	x						129026	
VTG	x				1		129026	
ZDA	x				1		129033	

8

Drawings

AP70 Control unit

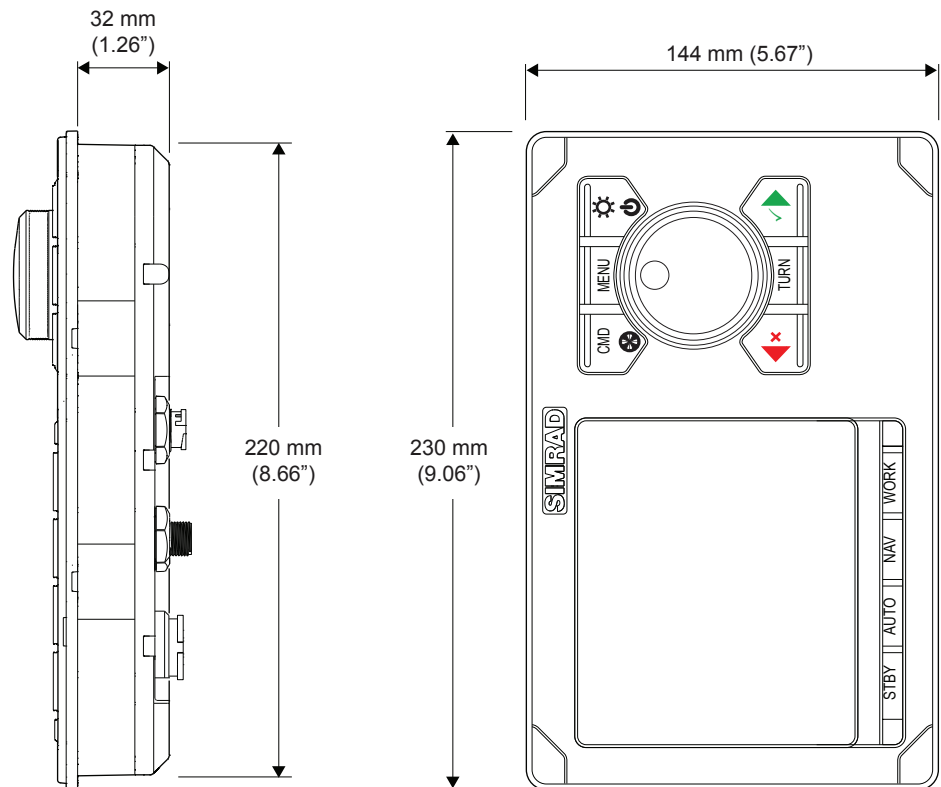
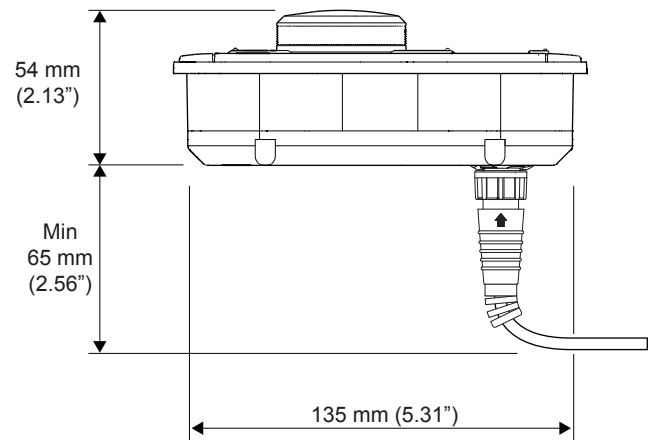

AP80 Control unit

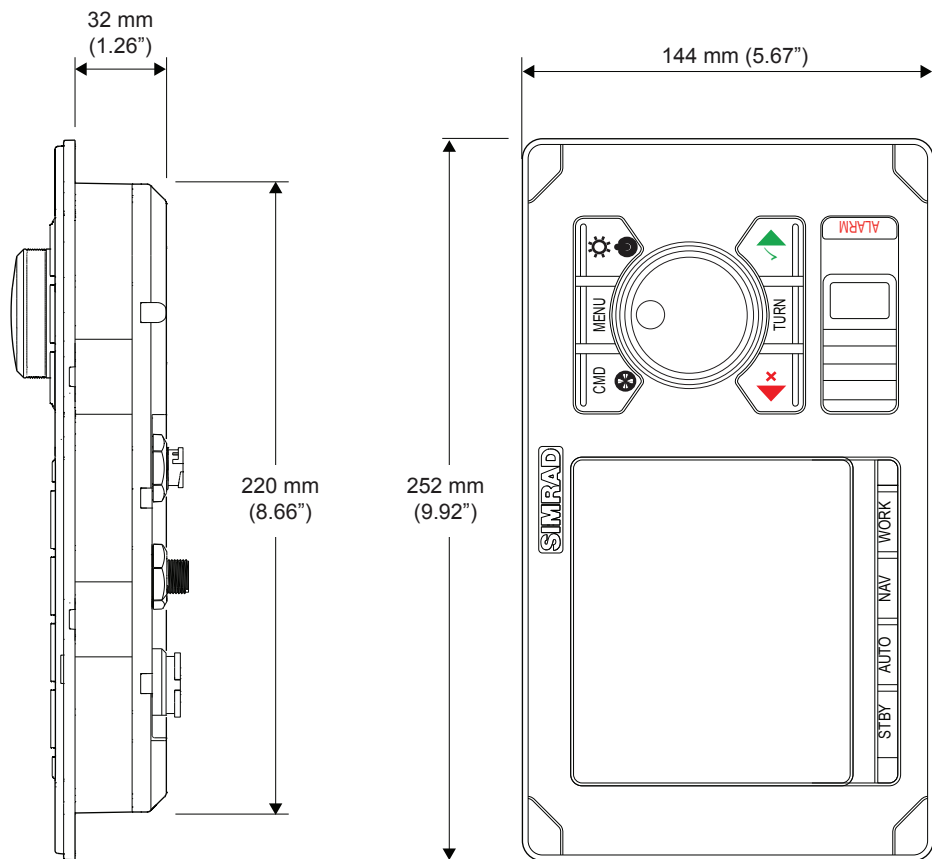
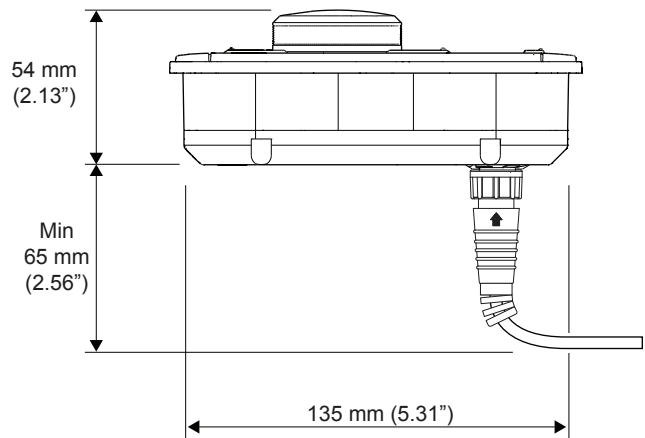

AC70 and SI80 Computer

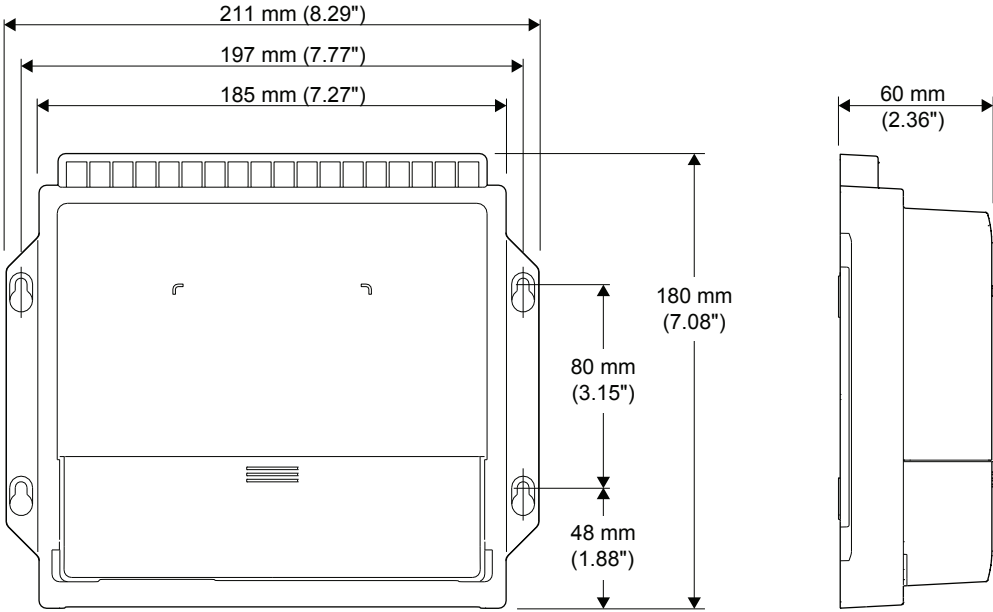

SD80 and AD80 Computers

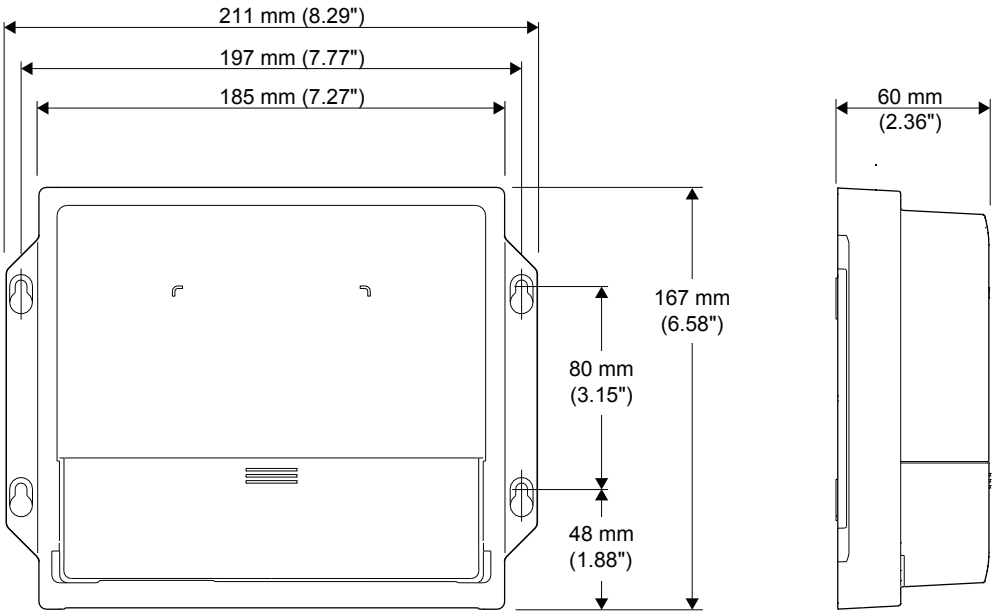

AC80A and AC80S Computer

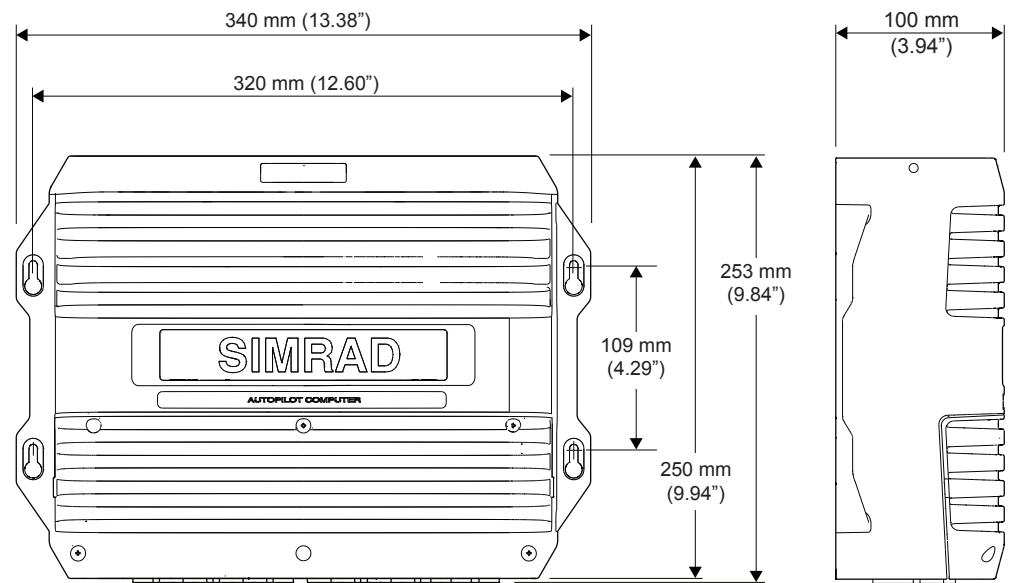

AC85 Computer

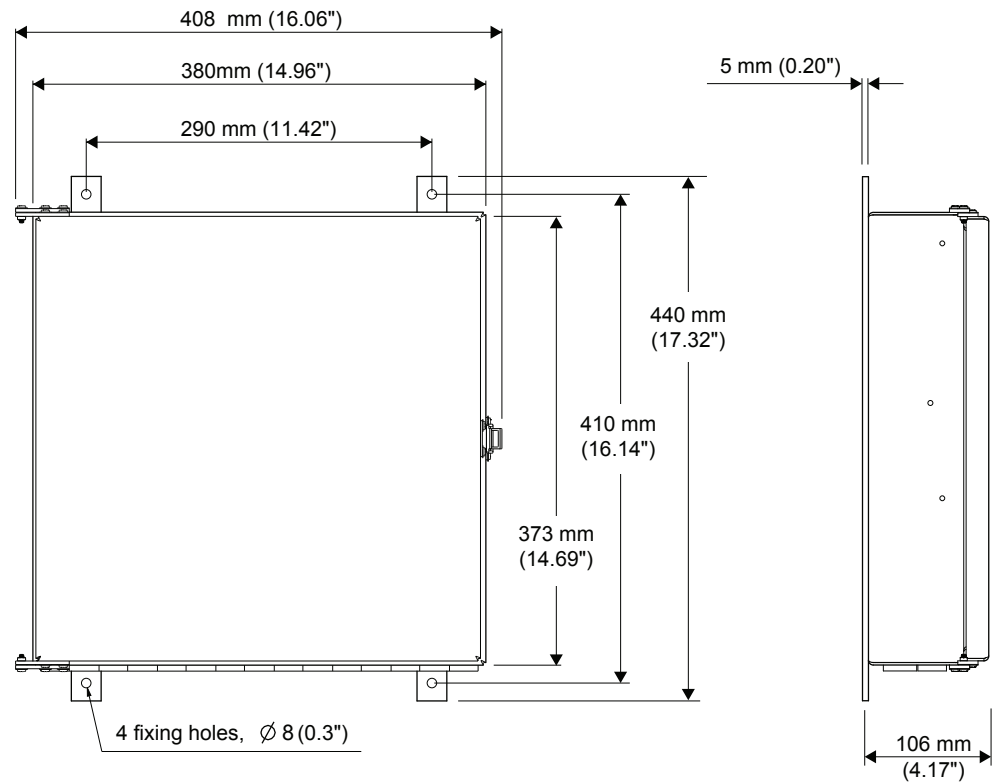



SIMRAD

